



NEWLONG INDUSTRIAL CO., LTD.

SEWING HEAD

DS-9

袋口縫ミシン

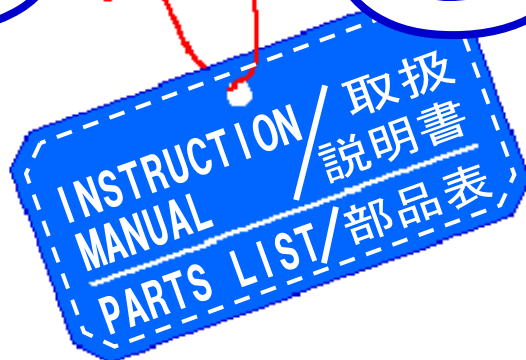

MODEL

DS-9A
DS-9C
DS-9P
DS-9AW
DS-9CW



ニューロング工業株式会社

NLIF-006

For Operator Safety

安全について

Thank you for purchasing the NLI Model DS-9 Bag Closing Machine Head.

ニューロン工業(株)DS-9 型袋口縫ミシンをお買い上げいただき有り難うございます。

- This manual contains the instructions and precautions for using the Model DS-9 Bag Closing Machine Head. Be sure to read and understand this manual before use and use the machine correctly.
- Keep this manual near the sewing machine for easy reference. Be sure to attach this manual to the machine when lending or transferring it to another person or company.
- Please order this manual from the nearest NLI office if it is lost.
- The contents of this manual are subject to change without prior notice for improvement and safety purpose.

- この取扱説明書は DS-9 型袋口縫ミシンの取扱い方法と使用上の注意事項が記載されています。ご使用前にこの取扱説明書を必ずお読みください。内容を十分理解して正しくご使用ください。
- この取扱説明書はミシンのそばに、いつでもご利用いただけるよう、保管してください。DS-9型袋口縫ミシンを貸し出し、または譲渡の場合はこの取扱説明書を機械に添付してください。
- この取扱説明書を紛失された場合はニューロン工業(株)全国連絡所にご注文ください。
- この取扱説明書は機能向上または安全のため、予告なしに変更することがあります。



Instructions with this mark are especially important for operator safety. Be sure to observe these marked instructions.



印のマークは安全上特に重要な項目です。必ずお守りください。



Hazard of Injuring the Fingers

The Model DS-9C sewing Machine head is provided with a built-in automatic tape/thread cutter. The operator's fingers may be injured by the cutter. A "hazard of injuring the fingers" mark is attached to the sewing machine. Do not put your fingers in or near the cutter when the machine is running.



切断危険

DS-9C型自動カッター付ミシンを使用中はカッターの作動で、指にケガをする恐れがあります。ミシンには危険マークを貼っています。カッター刃の近くに手を出さないでください。



Hazard of Being Caught in the Machine

- Be careful, when you insert a bag to be closed into the sewing machine, or your fingers may be caught in the machine between the presser foot and feed dog.
- A "Hazardous" mark is attached to the machine. When sewing, be sure to support the bag with the hand from beneath the sewing head and not to touch on the machine.



巻込注意

ミシンに袋を挿入する時は、注意しないと針や押工金に指が巻き込まれるおそれがあります。ミシンには巻込注意マークを貼っています。指はミシンの下側を通るよう、手はミシンに直接さわらないように注意してください。

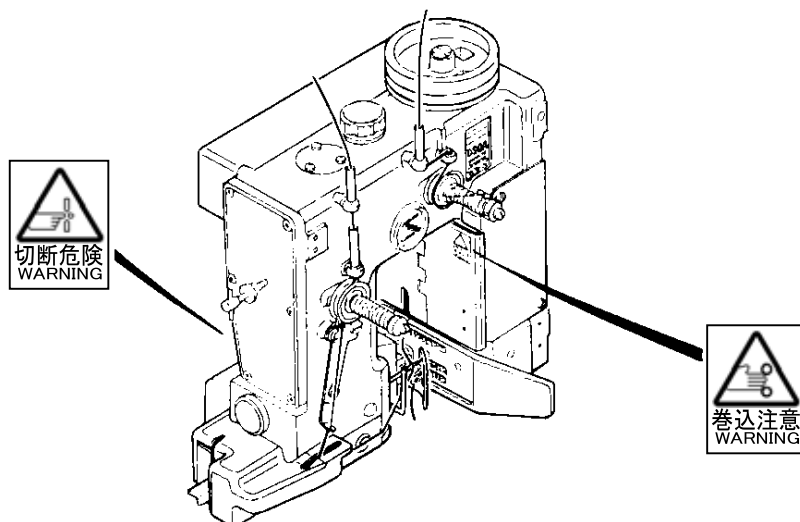

The instruction manual and parts list is subject to change without prior notice. この取扱説明書 / パーツリストは機能向上のため予告なしに変更することがあります。

WARNING

PERSONAL INJURY MAY RESULT IF THE FOLLOWING SAFETY PRECAUTIONS ARE NOT OBSERVED.

1. BE SURE THE AREA SURROUNDING MACHINE IS FREE OF ALL HAZARDS SUCH AS FIRE, WATER, OIL, RUBBISH OR ANYTHING THAT CAN CAUSE INJURY.
2. DO NOT OPERATE MACHINE IN AN EXPLOSIVE AREA OR UNDER WET CONDITIONS. THE MACHINE IS NOT AN EXPLOSION-PROOF TYPE NOR WATER-PROOF TYPE.
3. DO NOT OPERATE MACHINE BEFORE READING INSTRUCTION MANUAL.
4. DO NOT OPERATE MACHINE ON VOLTAGES OTHER THAN SPECIFIED FOR THE MACHINE.
5. BE SURE MACHINE IS CONNECTED TO BUILDING ELECTRICAL SAFETY GROUND (EARTH).
6. BE SURE POWER (AND AIR SUPPLY) IS OFF BEFORE PERFORMING MACHINE MAINTENANCE, PARTS REPLACEMENT, ADJUSTMENTS OR CLEANING.
7. DO NOT OPERATE MACHINE WITH GUARDS AND COVERS REMOVED.
8. DO NOT TOUCH KNIFE, NEEDLE, PULLEY, BELT AND MOVING PARTS WHEN MACHINE IS IN OPERATION.
9. BE SURE MACHINE IS PLACED ON A SMOOTH (LEVEL) SURFACE WHEN PERFORMING MAINTENANCE, PARTS REPLACEMENT, ADJUSTMENTS, CLEANING OR STORAGE.
10. BE SURE THE MATERIAL TO BE SEWN OR CLOSED COMPLIES WITH THE MACHINE SPECIFICATIONS.
11. DO NOT USE SPARE PARTS OTHER THAN " NLI " GENUINE PARTS.

警告

下記の安全項目を順守しなかった場合には事故の原因となりますので注意してください。

1. 機械の周辺に事故を起こす原因となる火気、水、油、可燃物などがないか確かめてください。
2. 爆発の危険のある環境・水滴が直接機械にかかる環境では使用しないでください。この機械は、防爆型・防滴型ではありません。
3. 取扱説明書を必ず読んでから機械を運転してください。
4. 機械の指定電圧以外では運転しないでください。
5. アース線が接続されている事を確認してください。
6. 機械の整備・部品交換・調整・又は掃除の前に必ず電源（及びエア源）を切ってください。
7. 蓋やカバーが外れた状態では機械を運転しないでください。
8. 機械の運転中はカッター、針、プーリー、ベルトその他動いている箇所には手を触れないでください。
9. 機械の整備・部品交換・調整・掃除や保管の時には平らな場所に置いてください。
10. 縫おうとする素材が機械の仕様に合っているか確かめてください。
11. “ニューロン工業(株)”純正部品以外は使用しないでください。

Identifying and Ordering Parts

Where the construction permits, each part is stamped with its part number. On all orders, please include part number, part name and model name of machine.

Safety Rules

To prevent personal injury:

- All power sources to the machine must be turned off before threading, oiling, adjusting or replacing parts.
- All cover and guards must be in position before operating machine.
- Do not tamper with safety cover, guards, etc., while machine is in operation.

Cautions When Using the Machine

Safety Precautions

- 1) Always turn power off before threading, oiling, and adjusting the machine or replacing parts.
- 2) Wear safety glasses.
- 3) Make sure, before starting the machine, that all covers and shields are in place and closed.
- 4) Do not touch on the machine when it is run.
- 5) Turn power off and make sure the cutter does not operate before you put your fingers under the cutter blades and the needles to adjust.
- 6) Do not touch on the machine when it is run.

Maintenance

- Please keep in mind to handle the machine carefully and to maintain the machine in good condition.
- Thread fuzz or dust must be cleaned with air or brush on throat plate, in the groove of feed dog or around looper after the day's work.
- Wipe the area easy to rust with oil cloth.
- Check the machine for loose screws and tighten them, if any, once a month.
- Good maintenance will prolong the machine life.

サービスに関するお問い合わせ

部品交換とご注文上の注意

- ニューロン工業(株)全国連絡所にはDS-9の純正部品を常備しております。
- ご注文の際は、パーツリストのパーツ番号と名称でご指示ください。
- 使用上ご不明な点及び使用中の故障や不審な点、その他整備などで解りにくい場合は、お買い上げいただきましたニューロン工業(株)全国連絡所にご連絡ください。尚その際、機種名、機械番号、ミシン頭部名、ミシン番号をご指示くださいますようお願いいたします。

使用上の注意

安全について

- 1) 袋詰まり・糸切れのときの糸通し、糸の交換、給油、調整、部品交換、保守点検作業の前に必ず電源を切ってください。
- 2) 調整作業のときは安全メガネの使用をおすすめします。
- 3) 全ての蓋・カバーは必ず運転前に閉めてください。
- 4) カバーなどが閉まっていることを確認してから運転してください。
- 5) 針の下に手を入れるときは、必ず電源を切ってください。修理調整のときは、必ず電源を切りミシンが動かないことを確認してから作業を行ってください。
- 6) ミシンの運転中には、ミシンに触れないでください。

整備

- ミシン頭部は精密な小さな部品から出来上がっています。注意深く取扱うとともに常に整備に心掛けてください。
- 一日の作業が終了しましたら、針板の上、送り金の溝の中、ルーバーのまわりに集まったほこり等はきれいに取除いて下さい。
- その他錆易い箇所は油布等で拭いてください。
- 月に一度はネジの緩みがないか点検してください。
- 手入れの良し悪しは機械の寿命に影響しますのでご注意ください。

CONTENTS/目次

1.Specifications/仕様	2
2.The Points Before Operation/運転前の確認	2
3.Threading/糸通し	3
1. DS-9A,9C,9P	3
2. DS-9AW,9CW	3
4.Oiling/給油	4
1. Oil Filling 注油	4
2. Exchanging Oil 油の交換	4
5.Adjusting/調整	5
1. Thread Tension 糸調子の調整	5
2. Presser Foot Pressure 押工金の調整	5
3. Looper ルーパーの調整	6
4. Feed Mechanism 送り金の調整	8
5. Thread Cutter ナイフの調整(DS-9A)	10
6. Cutter カッターの調整(DS-9C)	10
7. Adjustment for Single Thread Sewing 単環縫いの調整	12
6.Trouble Shooting/ミシンのトラブルの原因と対処	13, 14
Parts List/部品表	15~39
List of Screw, Nut & Washer/ネジ、ナット、ワッシャー一覧図	40, 41
Numerical Index of Parts/パーツ索引	42~44

1. Specification/仕様

Model	DS-9A	DS-9C	DS-9P	DS-9AW	DS-9CW
Max. Speed 最高回転数	2700rpm			2500rpm	
Ordinary Speed 常用連続回転数	2500rpm			2300rpm	
Stitch Length 縫目巾	7-11.5mm	7-10.5mm	7-11.5mm	7-11.5mm	7-10.5mm
Stitch Type 縫目形式	Double thread chain stitch 2重環縫い				
Needle Type and Size 針の形式、サイズ	DR-H30#26		DRG-67#27	DR-H30#26	
Cutter カッター	Thread Cutter 糸切りカッター	Crepe Tape Cutter クレープカッター	- カッター無し	Thread Cutter 糸切りカッター	Crepe Tape Cutter クレープカッター
Lubrication 給油方式	Totally enclosed oil bath 完全密閉型オイルバス				

Model 機種名 Part 部品名	DS-9A	DS-9C	DS-9P	DS-9AW	DS-9CW	Purpose 用途
Presser Foot, left 押工金組(左)	062251A	102135A	302161A	062391A	102281A	Standard 標準
Presser Foot, right 押工金組(右)	062261	102162	-	062381	102261	
Feed Dog, front 送り金(前)	304211	304131	304221	304291	104231	
Feed Dog, rear 送り金(後)	-	104072	-	-	104072	
Throat Plate 針板	304181	104123	304231	304281	104241	
Presser Foot, left 押工金組(左)	-	102134A	-	062392A	102311A	Hand feed 手差し用
	-	102136A	-	-	-	Sub-Tape 当て紙用
	-	102321A	-	-	102331A	Bag Mouth Holder 口折り機用
Presser Foot, right 押工金組(右)	-	102161	-	-	-	Hand Feed and Jute Bag 手差し用、麻袋用
Throat Plate 針板	-	104093	-	-	-	
	-	104122	-	-	-	by lever start ミンスタートレバー式
	304311	304171	304241	-	-	Single Thread 単環縫い用

2. The Points Before Operation/運転前の確認

- Oil the area through which thread passes, the tension disc, the thread guide, looper, etc.
(Note: An anticorrosive agent is applied to the machines at the factory, in order to prevent rusting. It is necessary to use oil to remove this agent. or it may prevent the thread from passing smoothly.)
- 解梱して、ミシンを初めて運転するときは、糸の通る箇所、糸調子・糸ガイド・ルーパーなどに必ず油を差してください。
ミシンには、錆の発生を防ぐため工場出荷時に錆止め油を塗っています。錆止め油を除去しないと糸がスムーズに流れないことがあります。
- Confirm that the machine has been threaded as per the instructions 3. in the manual.
- 運転前に必ず糸通しの説明を見て、糸通しが正しいことを確認してください。
- Confirm that the machine has been lubricated as per the instructions 4. in the manual.
- 運転前に必ず給油の説明を読んで、給油方法が正しいことを確認してください。

3. Threading/糸通し

1. For DS-9A,DS-9C,DS-9P<Fig.1-A. a b >
- Thread a on the left side of thread stand is Needle thread. Thread it points through in order.
 - Thread b on the right hand side of thread stand is Loper thread. Thread it points through in order.
 - Both threads should extend from the last threading point by 15 to 20cm.

Caution:
No stitching at all, or thread break or skipping stitches result if the machine is not properly threaded. Check the threading with <Fig.1-A,B>, and be sure both Needle thread and Loper thread are correctly thread.

1. DS-9A,DS-9C,DS-9P の場合<Fig.1-A. a b >
- 糸立ての向って左側の糸 a (上糸)を ~ まで順番に通してください。
 - 糸立ての向って右側の糸 b (下糸)を ~ まで順番に通してください。
 - 上糸は針から、下糸はルーパーから15cm~20cmぐらい長く出してください。

[注意]
糸の通し方を間違えますと、全然縫えないか、糸切れ、目飛びなどの原因となります。
<Fig.1-A,B>をよくご覧になって、上糸、下糸とも番号順に間違いなく通してください。

2. For DS-9AW,DS-9CW<Fig.1-B. a a b b >
- Needle Thread 1 a :Thread it points through in order
 - Needle Thread 2 a :Thread it points through in order.
 - Looper Thread 1 b :Thread it points through 21 in order.
 - Looper Thread 1 b :Thread it points through 21 in order.

2. DS-9AW,DS-9CW の場合<Fig.1-B. a a b b >
- 上糸 1 a は ~ までの順番に通してください。
 - 上糸 2 a は ~ までの順番に通してください。
 - 下糸 1 b は ~ 21 までの順番に通してください。
 - 下糸 2 b は ~ 21 までの順番に通してください。

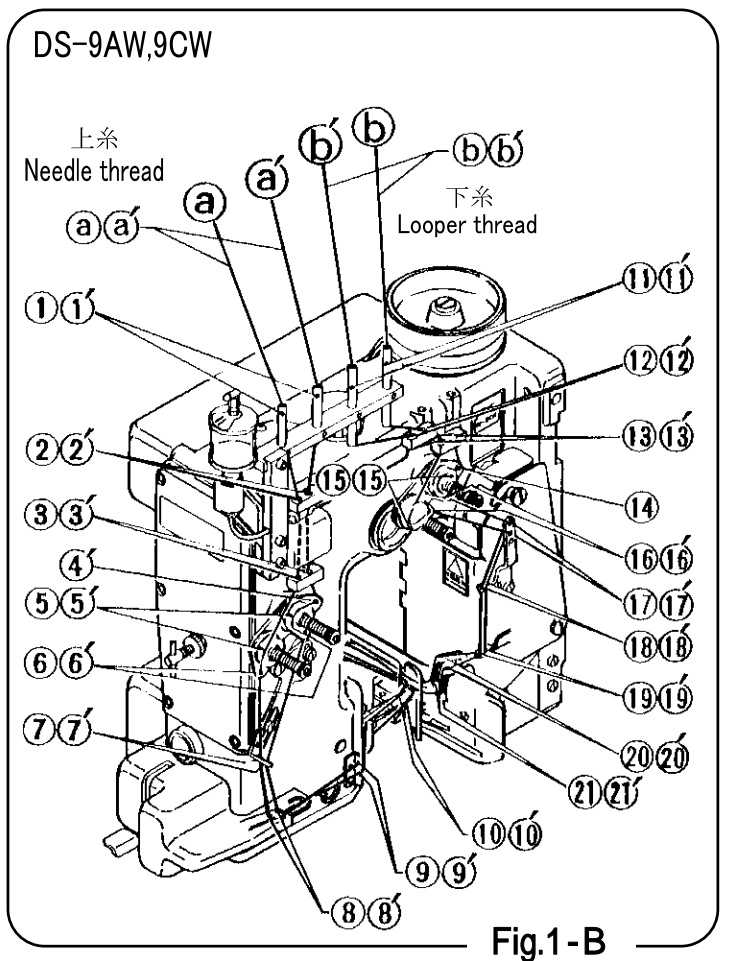
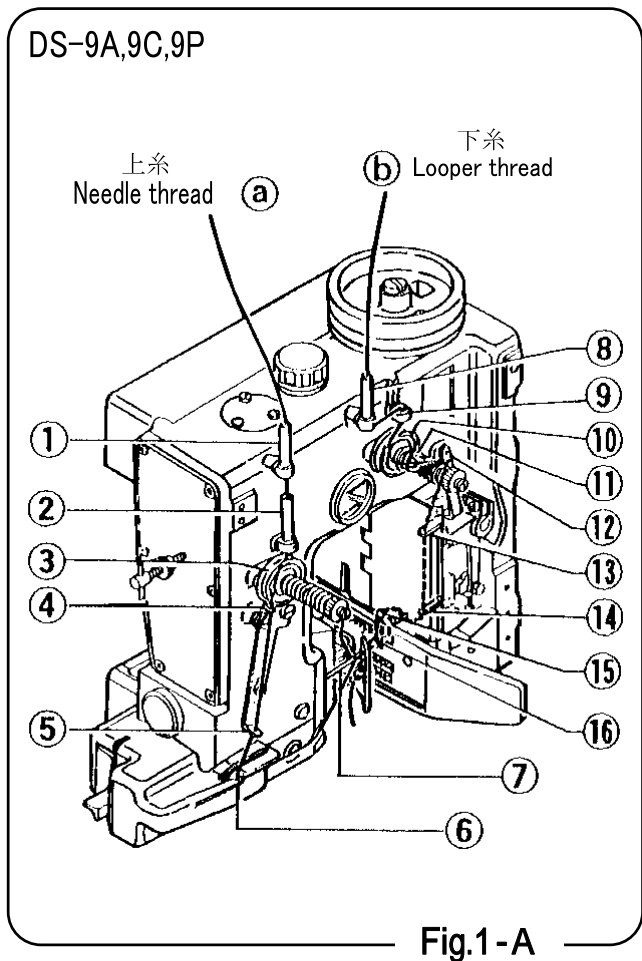

4. Oiling/給油

Oil is Completely drained from the machine before packing. Ensure the machine is filled to the correct levels as described below. Use mineral oil 22-32 cSt at 40 . (Eg. Tellus oil #32.)

1. Oil Filling

- a) Unscrew breather cap a and fill with oil to between the maximum and minimum levels A .
Approximately 1,600cc should be used. (Fig.2)
- b) Remove cover b and fill with oil so that level reaches the red point indicator B . Approximately 140cc should be used. (Fig.2)

2. Exchanging Oil

- a) Oil should be exchanged after the first 1,000 hours of operation then after every 2,000 hours.
- b) Oil Draining
As indicated (Fig.2) oil is drained from the machine by rotating and un-plugging C , D .

DS-9 型マシンは完全密閉型オイルバス式マシンですが、油を抜いた状態で出荷しています。初めて運転するとき、かならず注油してから運転してください。

- 注油するところは2カ所ありますので、注意してください。
- 注入する油は、40 での動粘度 22cSt ~ 32cSt の鉱油を使用してください。
(例) シェルテラスオイル#32
- 相当長期間使用しないマシンの再使用については、弊社技術員に相談ください。

1. 注油

- a) オイルレベル A 部に油を注油するには a の給油口蓋をはずしてオイルレベルのレベル“H”まで注油してください。注油量は約 1600cc です。(Fig.2)
- b) オイルレベル B 部に油を注油するには b の給油口蓋をはずして赤丸の部分まで注油してください。注油量は約 140cc です。(Fig.2)

2. 油の交換

- a) 最初は、稼働時間 1000 時間で、油を交換してください。2回目以降は 2000 時間ごとに油を交換して下さい。
- b) 油を抜くときは、図のようにプラグ C , D をはずしてください。(Fig.2)

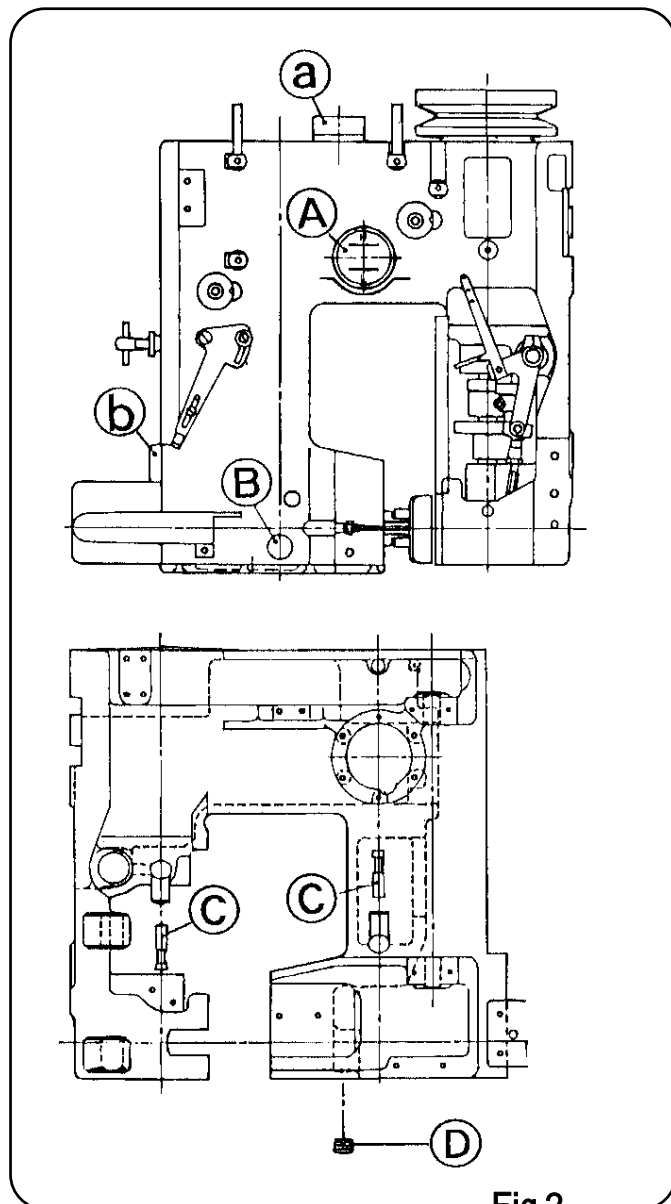

Fig.2

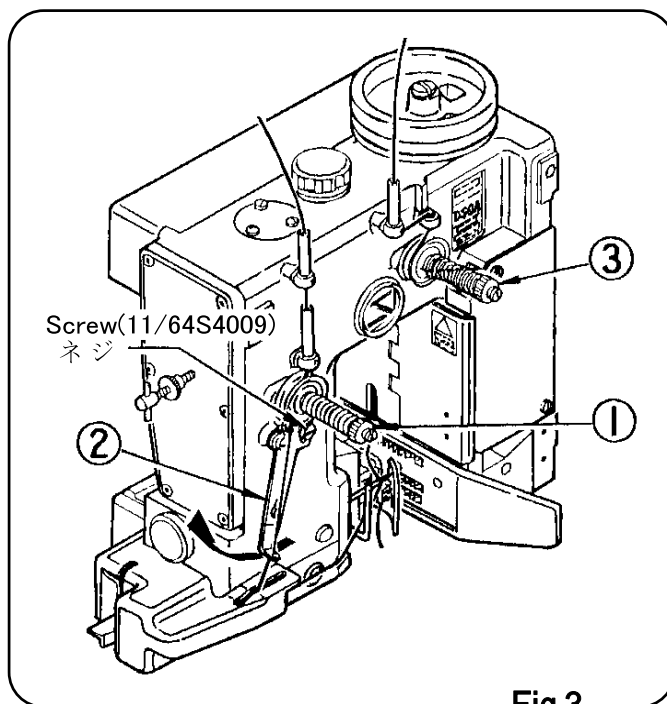

Fig.3

5. Adjusting/調整

The looper movement of this machine has been properly adjusted before shipment from the factory, but if it needs re-adjustment when it is disassembled for repair or etc, proceed as follows.

1. Thread Tension (Figure 3)

Thread tension is most important for successful sewing, Maladjustment results in thread break, skipping stitches and break of bag.

Proper thread tension may slightly vary with the type of bag and thread. The norm is given below. Thread tension regulators are mounted so that the tension is uniform for stitch length. To adjust the tightness of seam, adjust , in Figure 3.

1) Heavy material (jute,etc.)

Thread tension regulators should be loosened slightly (turn the adjust nut counterclockwise), Needle thread controller after loosening set screw.

2) Light material

Tighten thread tension regulators (turn the adjust nut clockwise).

3) Needle thread

At the shipment, the needle thread controller for Creped Paper Tape is adjusted a little downward. In case of using sewing machine without Creped Paper Tape, the needle thread controller should be re-adjusted upward.

The feed rate of thread must be adjusted according to stitch length and thickness of bag. If thread tension regulator adjustment is not sufficient for obtaining the required thread tightness, use needle thread controller by moving it up or down as necessary, after loosening set screw. Thread is tighter by moving it up (in the direction of the arrow), and is looser by moving it down. Tighten the set screw after adjustment.

4) Looper thread

Looper thread tension regulator should be adjusted in accordance with adjustment of the needle thread tension regulator. Adjust it so that the looper thread will not sag. If looper thread tension is too much, the needle thread may break.

2. Presser Foot Pressure

Presser foot pressure must be adjusted according to the material of bag and thickness. Check the reverse side of seams. The pressure is too strong if seams show a sign of scratches by feed dog teeth, or the actual stitch length is shorter than the preset feed rate of feed dog teeth. In this case, unscrew plate spring adjust screw(102171),Figure 4, after loosening nut (5/16N24301). Be sure to tighten the nut after the adjustment. If the pressure is too weak, seams do not form a straight line, or the stitch length is irregular. In this case, increase the pressure by screwing the plate spring adjust screw. Decrease the pressure when closing jute and other heavy bag material, and increase it when closing PP woven cloth and other light bag material. Your machine is adjusted for 3-ply kraft paper bags at the factory.

DS-9型ミシンは、弊社で適正に調整をして、出荷していますが、部品交換などで調整が必要になりましたら、次の調整方法を参照に、調整してください。

1. 糸調子の調整 (Fig.3 参照)

糸調子は袋を縫う上で最も重要な部分です。注意してください。糸調子の調整を間違えると糸切れ・目飛び・袋の破断などの原因となります。

糸調子<Fig.3- >の調整は袋と糸の種類で多少の違いがありますが、原則として次の通りに調整してください。

1) 厚物袋(麻袋など)使用の調整

糸調子の糸の押さえかたを比較的ゆるくしてください。糸調子スプリングを指で押し下げてから糸調子ナットを左へ(時計と逆方向に)回してください。糸調子スプリングがナットの裏側の溝に入ってナットの回転が固定されるまでまわします。確認してください。

(また上糸調節はネジを緩めてやや下げます)

2) 薄物袋使用の調整

糸調子の糸の押さえかたを強くしてください。糸調子ナットを右に回してください。

(また上糸調節はネジを緩めてやや上げてください)

3) 上糸調節の調整

工場出荷時はクレープテープ用に上糸調節を少し下げて調整しています。テープを使用しない時は上糸調節を上げて再調整してください。

縫い目幅、袋の厚さの違いで糸調子だけでは糸締まりが悪いときは上糸調節を上下させ調節します。上糸調節を矢印方向に上げると糸は締まり、逆の方向に動かすと糸は緩みます。適正な位置でネジ(11/64S40009)で上糸調節を固定してください。

4) 下糸の調整

下糸の糸調子の調整は上糸の糸調子に合わせます。下糸がたるまないように調整してください。下糸の糸調子の押さえ方が強いと、上糸の糸切れの原因となります。注意してください。

2. 押工金の調整

押工金の押工圧は袋の材質や厚さの違いで調節してください。縫った袋の裏側の縫い目を見てください。送り金によって傷がつき、また縫い目幅が送り量より小さいときは押工圧が強すぎます。板バネ調節ネジ(102171)を緩めて調節して下さい。そのあとナット(5/16N24301)をしっかり締めてください。押工圧が弱いと縫い目が直線に縫えず、また縫い目幅も不揃いになります。前述の調整と逆に調節ネジを締めてください。麻袋など厚物の袋を縫うときは押工圧を弱くしてください。PPクロス袋など薄物の袋を縫うときは押工圧を強めにしてください。工場出荷のときはクラフト3層の紙袋に合わせた調整をしています。

5. Adjusting/調整

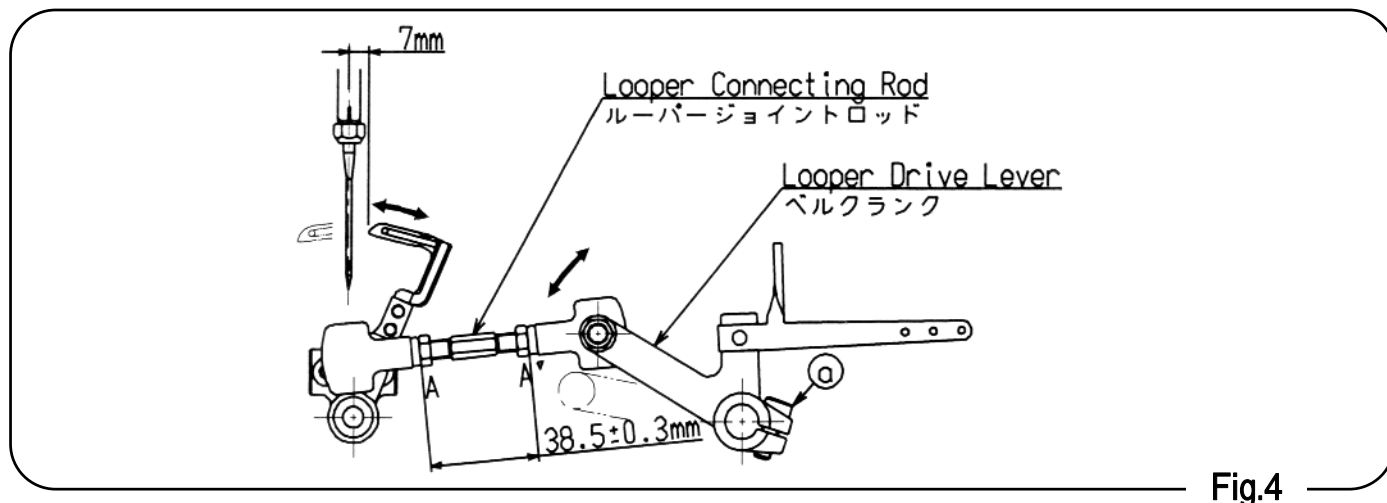

Fig.4

3. Looper

a) Distance between Needle and Looper

Turn the pulley in the forward direction and adjust the bell crank so that the end of the looper is 7mm away from the needle center when the needle is in the most retracted position, as shown in (Fig.4). The distance between the nut (outside) of Looper Connecting Rod must be $38.5 \pm 0.3\text{mm}$. (Fig.4)

Upon completion of the adjustment, tighten the screw of the bell crank.

b) Check of Height of Needle

Needle and looper movements are correctly timed if distance (A and A' of Fig.4) between Looper point and Needle hole when Looper points gets in line with left-side edge of Needle is the same as Looper passes Needle in forward and backward movements. $A=A' \pm 0.3\text{mm}$ is allowable. Adjust by lightly tapping the looper Drive Lever. Looper eyelet should overlap with lower part of oval hole of Needle, as shown in (Fig.5-c.) as looper goes forward. Adjustment can also be done by loosening the set screw of the needle bar connecting stud and adjusting the height of the needle bar so that the end of the needle is 15.5mm from the upper surface of the throat plate as shown in (Fig.6).

3. ルーパーの調整

a) 針とルーパーの距離

あらかじめボールジョイントロッドの、図の距離(A-A)を $38.5\text{mm} \pm 0.3\text{mm}$ 以内にして取り付けてください。(Fig.4) ルーパーが最も後退したとき針芯とルーパーの距離は 7mm です。

この調整は、ベルクランクのネジ a を緩めてベルクランクを調整し、締め付けてください。この時ベルクランク軸にガタ(隙間)ができないように注意してください。

b) 針の高さ

- ルーパーの先端と、針の穴の寸法が同じになるように調整します。ルーパーを前進・後退させ、ルーパーと針が交差するときに、ルーパーの先端から針穴の寸法が同じになるよう($A=A'$)に調整してください。(Fig.5-a・b) $A=A' \pm 0.3\text{mm}$ は許容範囲です。
- ルーパーの先端と、針の穴の寸法があわない場合には、ベルクランク軸を、前または後ろ側から、プラスチックハンマーでかるくたたいて調整してください。
- $A=A'$ の寸法を確認した後で、(Fig.5-c)ルーパー穴の下面と、針穴の下面が一致するように、針棒抱きのネジをゆるめ、針棒の高さを調整してください。
- あらかじめ、(Fig.6)の通り針が最もあがったとき、針と針板の距離が 15.5mm になるように、針棒の高さを定めると、調整が容易にできます。
- 調整のあとで針棒抱きネジをしっかり締めてください。

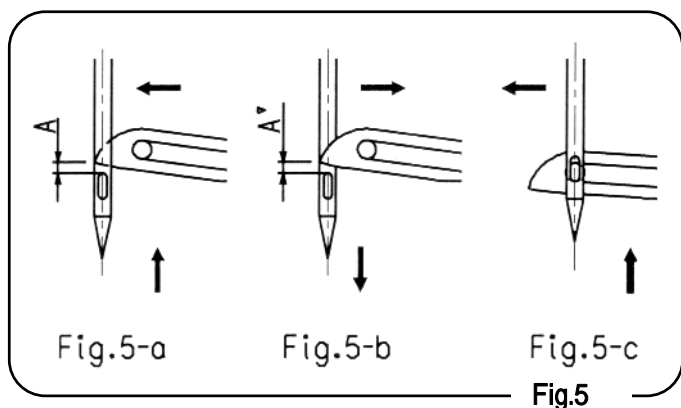

Fig.5

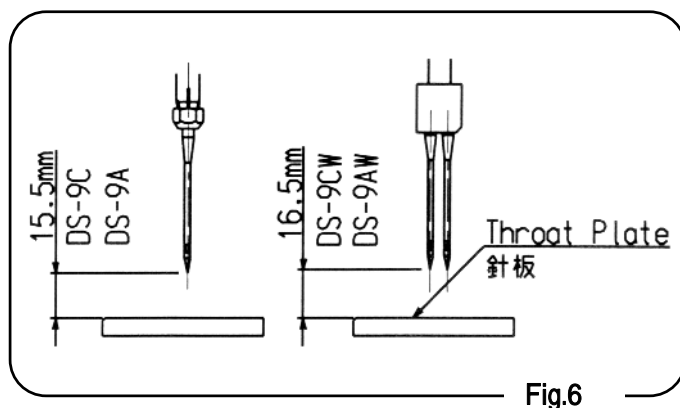

Fig.6

5. Adjusting/調整

c) Clearance Between Loooper and Needle

Adjust the clearance between the needle and the looper to between 0.05-0.1mm when the needle goes forward and passes the rear of the needle. To obtain the correct clearance, loosen the screw **b** of the looper rocker frame **a** and incline **c** the looper rocker. Adjust the clearance of the needle and looper to between 0.1-0.5mm when the looper moves forward to the right at the closest point to the needle.(Fig.7-a)

To facilitate the adjustment first adjust the looper avoid eccentric cam so that its screw is 45° to center of the main shaft.(Fig.7-b)

d) Clearance Between Loooper Retainer and Needle

Loosen set screw **d** and adjust the clearance of the needle and looper retainer to between 0.05-0.1mm as the needle goes up.(Fig7-c)

c) 針とルーパーの間隔

- 針のえぐりとルーパーとの間隔を調整します。ルーパーの先端が針の後ろを通過するとき、針のえぐりと、ルーパーの先端との間隔は、0.05～0.1mmに調整してください。
- ルーパー倒しアーム **a** のネジ **b** を緩めて、ルーパー台 **c** を倒して調整してください。
- 次に、ルーパーが前進から右に後退するとき、針のえぐりとルーパーの間隔は 0.1～0.5mm に調整してください。(Fig.7-a)
- ベルクランクが下がった位置で、ルーパー倒しカムを仮締めして、微調整をしてください。(Fig.7-b)

d) 針とルーブガイドの間隔

- ループガイドと針の間隔を調整します。針がもっとも下がった位置から、上昇するときに、ルーブガイドと針の間隔を 0.05～0.1mm になるように調整して下さい。(Fig.7-c)

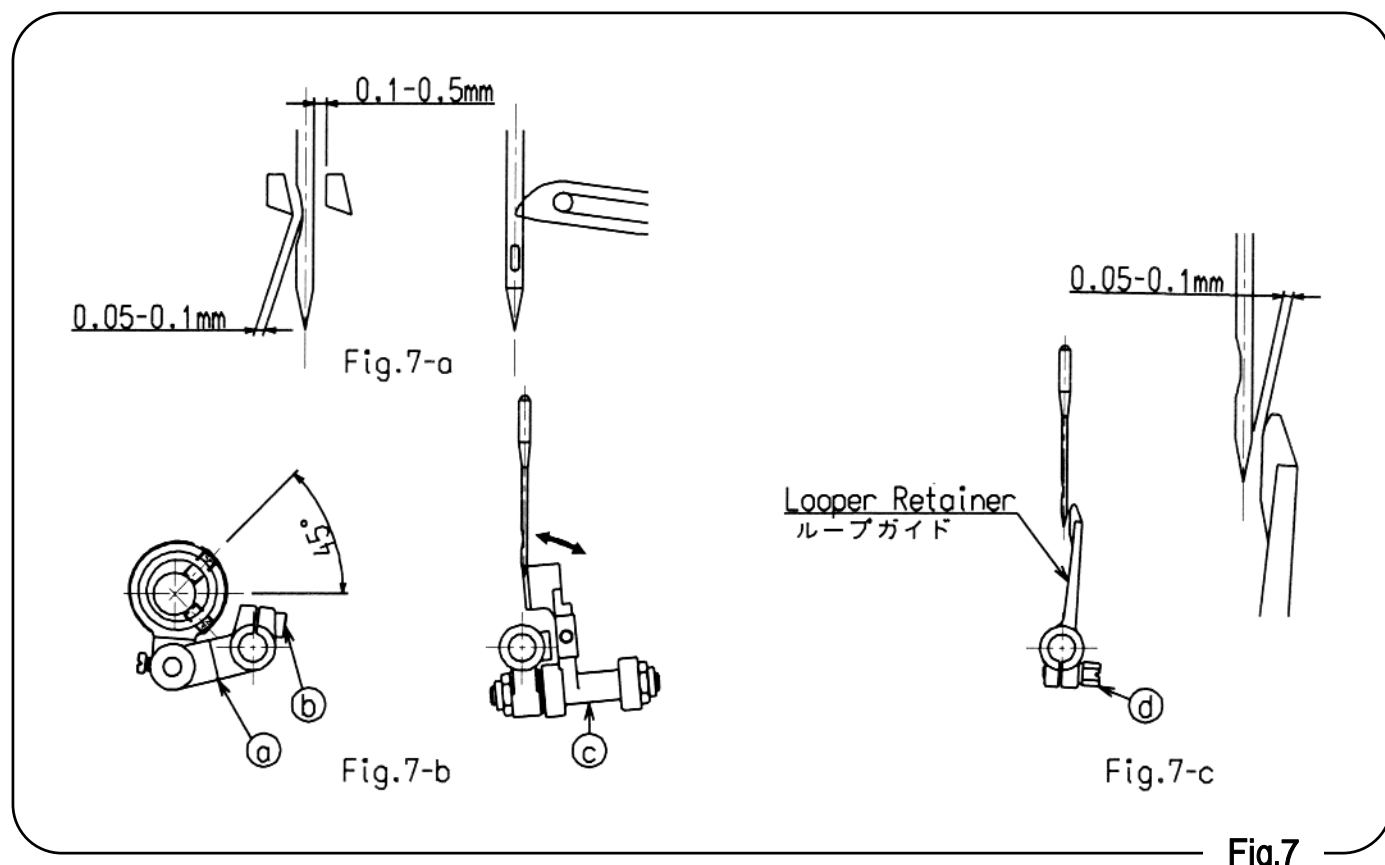

Fig.7

5. Adjusting/調整

4. Feed Mechanism

a) Clearance between Throat Plate and Feed Dog

Ensure that the feed dog does not touch the throat plate as it passes through. A clearance of 1.5mm should be seen between the middle teeth of the front feed dog and the throat plate as indicated (Fig.8).

b) Height of the Feed Dog

- Adjust the height of the feed dog so that it protrudes 2.5mm from the upper surface of the throat plate when the feed dog has risen to the highest position, as shown in (Fig.9). If the feed dog is higher than this, stitch will not chain satisfactorily, and if it is lower than this, the stitch width will be too small. Slacken nut **b** with a box spanner to adjust the height of the Feed Dog. It is important to adjust the height with set screw **a** to ensure that the pressure from the Pressure Foot should not force it back down. Tighten nut **b** when the adjustment is correct.
- The Rear Feed Dog should be set 0.1mm lower than the Front Feed Dog.

Caution:

Tentatively tighten the nut and make several stitches to be sure the required stitch length is obtained. After the confirmation, firmly tighten the nut with a spanner.

4. 送り金の調整

a) 針板と送り金の間隔

送り金がかっとも前進したとき、針板の溝と送り金の間隔は1.5mmです。(Fig.8)
送り元土台のネジを緩めて、調整してください。

b) 送り金の高さ

- 送り金(前)の高さは、送り金が最も上がったとき、針板上面から2.5mm出るように調整します。(Fig.9)
調節ネジ **a** を回して送り金が2.5mmでる位置になるように調整して下さい。調整が終わってから、ボックススパナでナット **b** を締めて送り金を固定してください。
- 送り金(後)は、送り金(前)に対して同じ高さか、0.1mmほど下げ気味にして取り付けてください。

[注意]

ナットを仮締めして調整が終わりましたらナット **b** をしっかり締めて下さい。

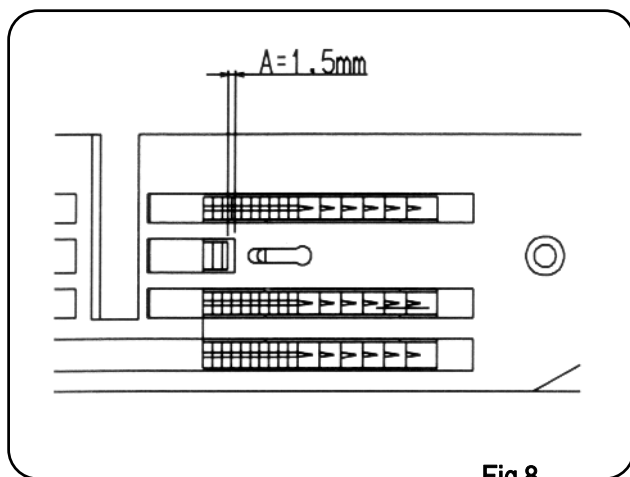

Fig.8

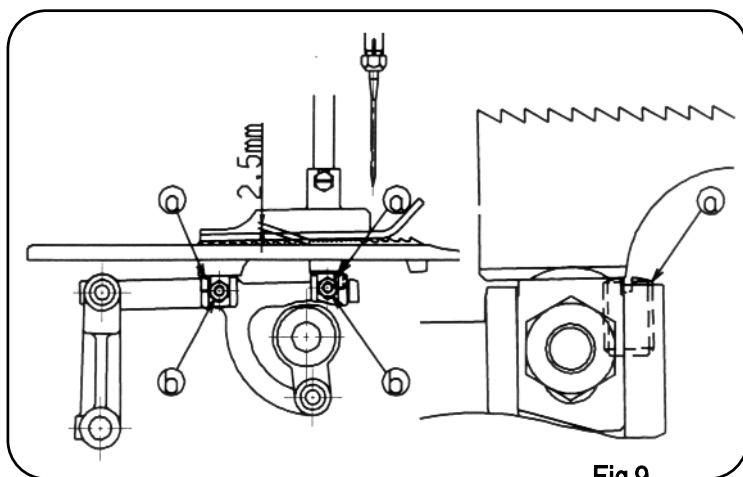

Fig.9

5. Adjusting/調整

c) Stitch Spacing

The stitch width of this machine has been adjusted to 10mm before shipment from the factory. The stitch width is adjustable from 7 to 11.5mm.

(only DS-9C is adjustable from 7 to 10.5mm)

Loosen the nut **a** of the feed regulator and move the feed connecting rod **b** in the direction of S, as shown in (Fig.10), to decrease the stitch width, and move the rod in the direction of L to increase the width. When moving the feed connecting rod, do so after confirming that the feed connecting rod can move freely along the slot in the feed rocker (Rotate the pulley in the forward direction until the feed dog is in the forefront position).

c) 縫い目幅

縫い目幅は 7～11.5mm の範囲で調整可能ですが、工場出荷のときは縫い目幅10mmに合わせて調整しています。縫い目幅の調整は(Fig.10)を参照ください。

(但し DS-9C は 7～10.5mm)

- 送り調節軸のナット **a** を緩めて送りロッド **b** を動かしてナット **a** を仮締めします。
- 送りロッドを S 方向に動かすと縫い目幅は細くなり、L 方向に動かすと縫い目幅はあくなります。
- 送りロッドを動かすときは、送りロッドが送り元弓の長穴にそって軽く動く状態にして調整してください。
- ナットを仮締めして調整が終わりましたら、ナット **a** をしっかり締めてください。

d) Needle Guide

When the stitch width is changed, the needle guide must be adjusted accordingly, as the clearance between the needle guide and the needle will change. Turn the pulley in the forward direction after loosening the screw **a** of Fig.11 and adjust the clearance between the needle and needle guide to zero when the end of the looper comes to the side of the needle, as shown in (Fig.11) and tighten the screw **a**.

d) 針ガイドの調整

- DS-9 型ミシンの縫い目幅は前述のように 10mm に調整してありますが、針ガイドも合わせて 10mm に調整しています。
- 針ガイドが最も前進したときに(Fig.11)の示すように針との間隔が 0mm になるようにネジ **a** を緩めて調整します。
- DS-9 型の場合は、縫い目幅をかえても針ガイドの調整は必要ありませんが、念のため再確認してください。

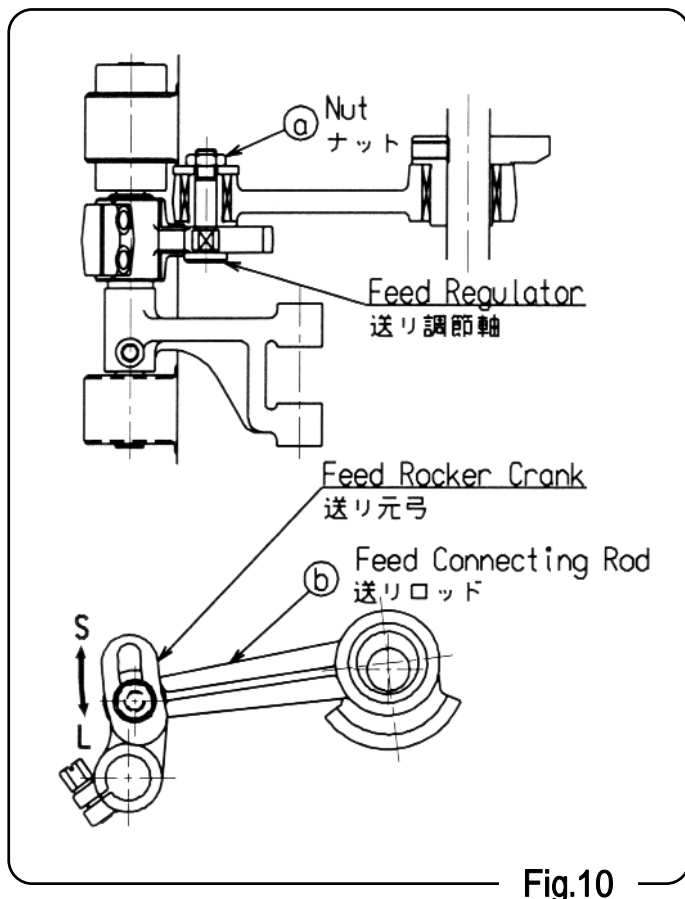

Fig.10

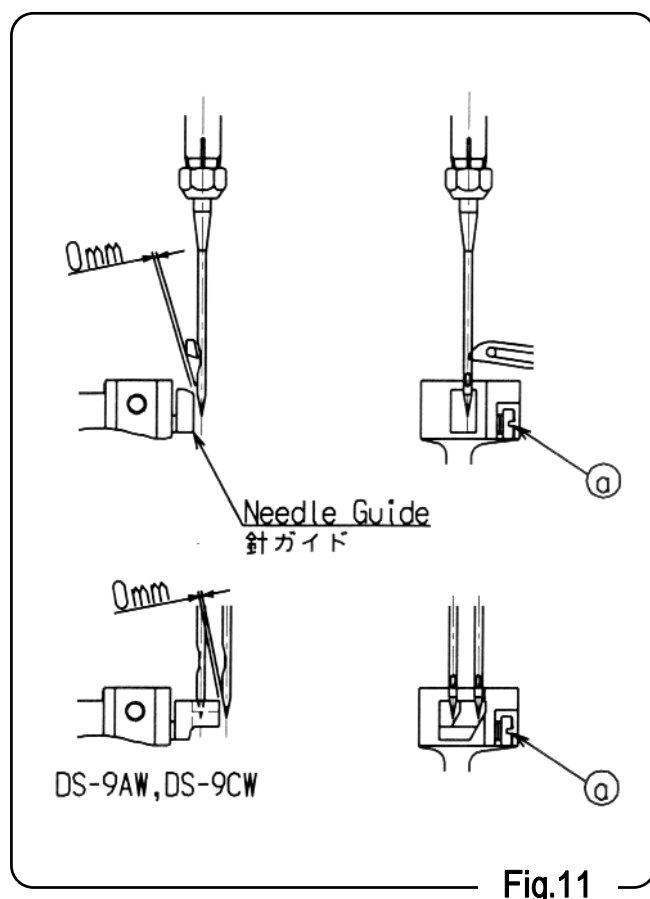

Fig.11

5. Adjusting/調整

5. Thread Cutter (DS-9A)

The knives, (A) and (B) are to be adjusted as following steps.

- Fix the knife (A) with tightening screw A at the proper position. Be sure that the knife edge does not protrude from thread gutter of throat plate.
- Fix the knife (B) in the gutter of knife lever, by tentatively tightening screw B.
- Turn pulley clockwise direction. When the knife (B) moves farthest right position, fix the knife (B) moves so that it contact with the edge of knife (A) approx, 2mm.
- Slightly bend knife lever to obtain proper contact between knife (A) and (B).
- Try to cut several threads wound and then confirm if they are cut sharply and straightly.

5. ナイフの調整 (DS-9A)

ナイフAとナイフBの噛み合わせは次のように調整してください。(Fig.12)

- ナイフAは固定刃土台の取り付け場所にネジで固定してください。空縫い糸が溝の中でさわらないよう、ナイフAの刃先は針板の糸溝からはみ出さないように注意してください。
- ナイフBはナイフレバーの溝にいれ、ネジBで仮締めしてください。
- プーリーをまわしてナイフBがもっとも前進したとき、ナイフAの刃先に2mmかみ合う位置でネジBを締めて固定してください。
- ナイフAとナイフBとのセリは(スパナなどを使用し)ナイフレバーを曲げて調整します。
- 糸5本を束ねてナイフA・Bの間に入れ、プーリーを手でまわして切ったとき、切れ残りがなく切断面が直角に切れているか、ナイフの切れ味を確認してください。

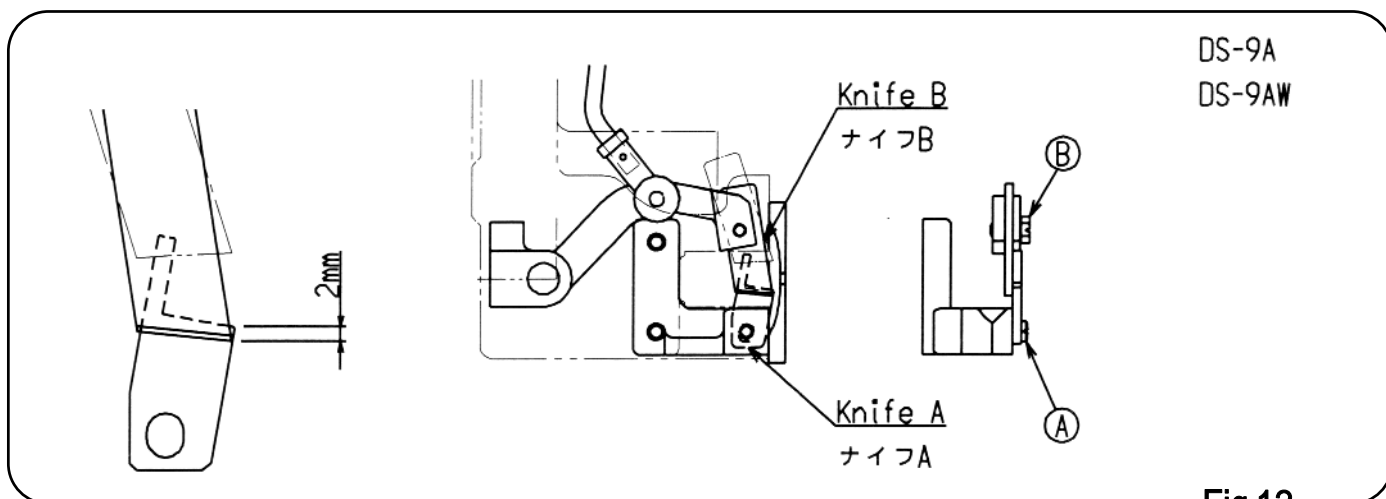

6. Cutter (DS-9C)

- To occlude the upper and lower blades, manually move the upper blade. To do so, put off air source. Here, prior to lowering the upper blade, loosen the screws a, b and h and the nuts C and d shown in (Fig.13).

When both blades are occluded, allow a gap of 0.1 to 0.2mm between the faces of the two blades on the rear side, and tighten the screw a and the nut d.

NOTE:

The gap adjustment can be easily made placing a sheet of Kraft paper between the upper and lower blades, as shown in (Fig.14).

- After the setting described in above, where the screw h is in light contact with the screw e, tighten the nut d.

6. カッターの調整

カッターの調整をする前に、必ずエア源を切ってください。エア源が切れていることを確認してください。上刃・下刃を交換するときは、いつでも調整が必要です。

- 手で上刃を動かして、上刃と下刃を噛み合わせます。上刃を下げる時(Fig.13)ネジ a, b, h ナット C, d は緩めてください。
 - 上刃と下刃の噛み合わせは(Fig.14)のようにうしろ側スキマが 0.1mm ~ 0.2mm になるようにネジ b で調整します。このとき上刃と下刃の先端側は、接触しているように調整してください。

[注意]

このスキマをとるとき(Fig.14)のように、上刃と下刃の間にクラフト紙1枚をはさんでいただければ、簡単に出来ます。

- この調整のあとネジ h をネジ e に軽くあてて、ナット d を締めてください。

5. Adjusting/調整

- c) After the adjustment by steps a and b, cut a crepe tape or thread for test. If the front end of the cutter cuts but the rear end does not, there is a gap on the rear side. In this case, loosen the nut d and loosen the screw h by 1/8 turn, and cut the thread again for test. If it still does not cut, loosen the screw by another 1/8 turn and repeat this adjustment and test cut until the thread can be cut, and then retighten the nut d. If the rear end of cutter cuts but the front end does not cut, the adjustment by step a is insufficient. Then, make re-adjustment of the rear side so that the gap between both the blades becomes 0.1 to 0.2mm. Here, adjust the upper and lower blades so that they are in contact with each other on the front side. If the lower blade tends to turn away without cutting, loosen the nut f and increase the pressure of the spring by turning the screw g clockwise. (Fig.13)
- d) Adjust the overlapped depth of the upper and lower blades by changing the length of air cylinder rod end so that the distance between the upper face of the lower blade and the rear side of the upper blade becomes 2mm, as shown in (Fig.14).
- e) Do not operate without Air Speed Controller on the Solenoid Valve of the Stand. (See the Parts List A2/A6(2L) page 12 Ref.No.49). In case of operating the Solenoid Valve without air Speed Controller, it will be the causation for some parts broken.
- f) Adjust air pressure to 0.4Mpa (4kg/cm²) not to exceed 0.5Mpa(5kg/cm²). In case of using with excessive air pressure (over 0.5Mpa(5Kg/cm²)), it will be the causation for some troubles.

- c) 前述 a, b の調整がすみましたら、手動でカッターを動かして、クレープ紙または糸を切断してみてください。
- カッターの先端側が切れて、後ろ側が切れない場合は、後ろ側のスキマが広すぎます。
 - ナット d を緩めて、ネジ h を 1/8 回転緩めてからクレープ紙または糸を再度切断してみてください。切れるところまでネジ h を 1/8 回転ずつ緩めて調整してください。切れるところでナット d を固定してください。
 - 後ろ側が切れて先端側が切れない場合は、a の調整が不良です。もう一度、上刃と下刃の後ろ側スキマが 0.1～0.2mm になるようにネジ b で調整します。また切断時に、下刃がにげるようでしたら、ナット f を緩めてネジ g を時計方向に回しスプリングの圧力を強くしてください。(Fig.13)

- d) 上刃と下刃の噛み合わせは 2mm です。シリンダーロッドとロッドエンドの接続長さをかえて、(Fig.14)を参照に、上刃と下刃の噛み合わせの深さを 2mm に調整してください。
- e) スタンド側の電磁弁にエアースピードコントローラーを必ず取り付けて使用してください。(パーツリスト A2/A6(2L) の 12 ページ図番 49 参照)。取付けない場合は部品破損などのトラブル発生の原因になります。
- f) エアー圧は 0.4Mpa(4kg/cm²)から 0.5Mpa(5kg/cm²)に合せてください。
0.5Mpa(5Kg/cm²)を超えて使用すると、部品破損などのトラブル発生の原因になります。

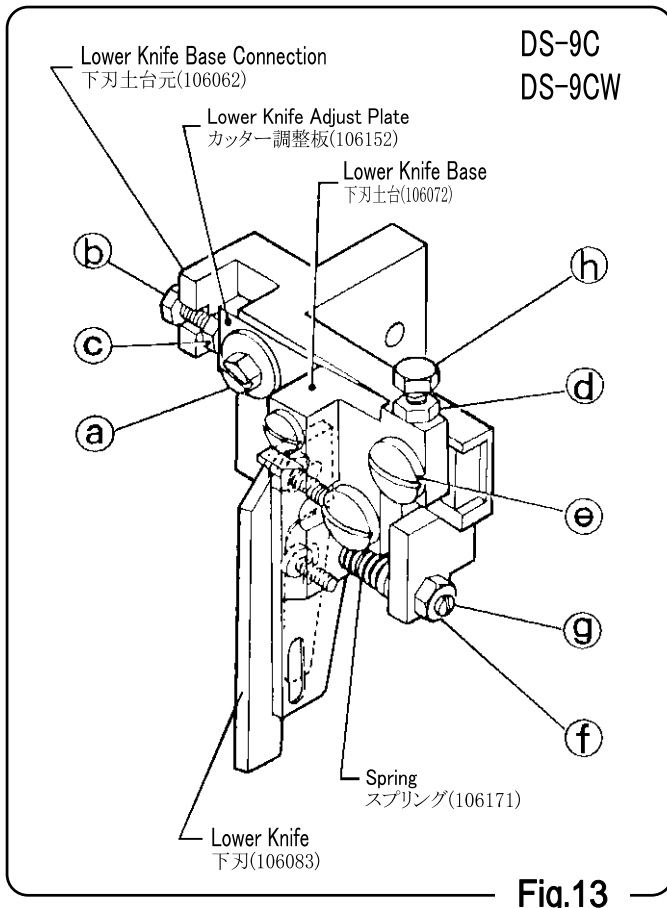

Fig.13

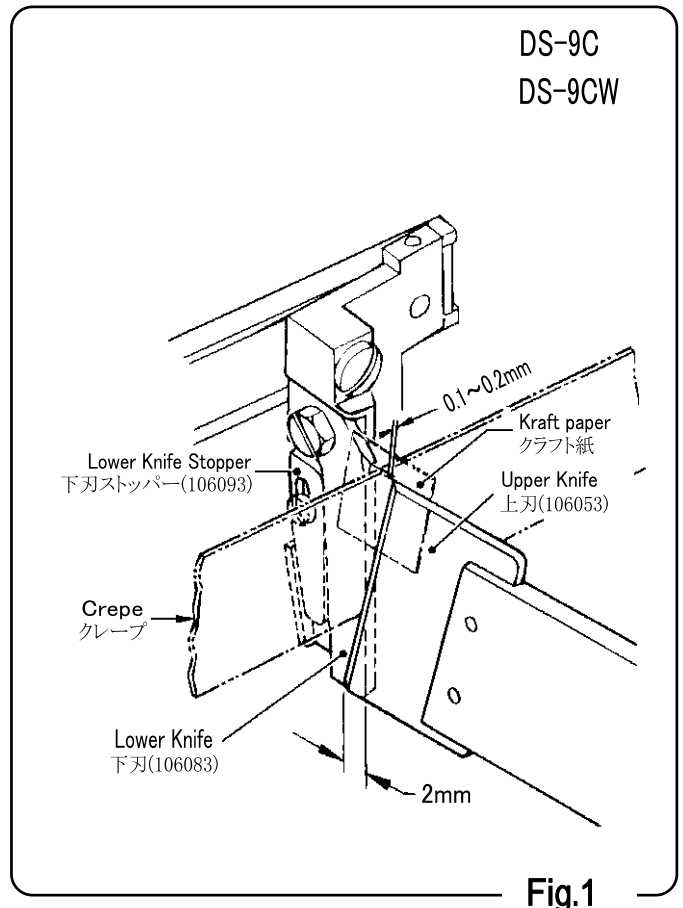

Fig.1

5. Adjusting/調整

7. Adjustment for Single Thread Sewing

- a) Fixing Throat Plate Thread Retainer (Fig.15)
 Fix Throat Plate Thread Retainer **b** at Throat Plate **a** with Screw **c**, keeping its point having 0 ~ 0.3mm clearance from Needle center.
- b) Clearance between Needle and Loper (Fig.16)
 Turn the pulley in the forward direction and adjust the bell crank so that the end of the looper is 7.5mm away from the needle center when the needle is in the most retracted position. The distance between the nut (outside) of Loper Connecting Rod must be 39.5 ± 0.3mm.
 Upon completion of the adjustment, tighten the screw of the bell crank.
- c) Adjustment between Loper and Throat Plate Thread Retainer (Fig.17)
 Adjust Throat Plate Thread Retainer with Loper Connecting Rod, keeping it not touching concave part of Loper when Loper pass through the nearest position A from Throat Plate.
- When the test to run, if the thread does not slip out smoothly from Throat Plate Thread Retainer, adjust keeping its point having 0 ~ 0.5mm from Needle center.

7. 単環縫いの調整

- a) 針板爪の取付 (Fig.15)
 針板爪 **b** の先端が針芯より 0 ~ 0.3mm になる位置で針板爪を針板 **a** にネジ **c** にて取付ける。
- b) 針とルーパールの調整 (Fig.16)
 あらかじめボールジョイントロッドの、図の距離 (A-A') を 39.5mm ± 0.3mm 以内にして取り付けてください。ルーパーが最も後退したとき針芯とルーパールの距離は 7.5mm です。この調整は、ベルクランクのネジ **f** を緩めてベルクランクを調整し、締め付けてください。この時ベルクランク軸にガタ (隙間) ができないように注意してください。
- c) ルーパーと針板爪の調整 (Fig.17)
 ルーパーが **A** 点で前後に倒れる時、針板爪がルーパールの逃げ溝に当たらないようにルーパージョイントロッドを調整する。
- 試し縫いをして糸が針板爪に引っ掛かりが強い場合は針芯より 0 ~ 0.5mm に引っ込めて調整する。

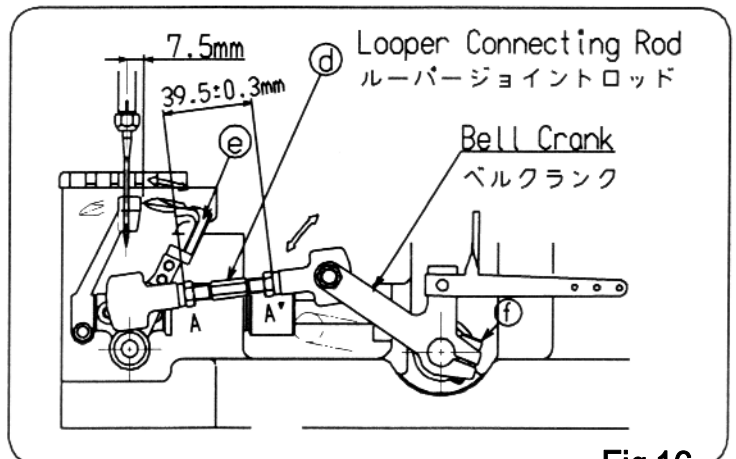
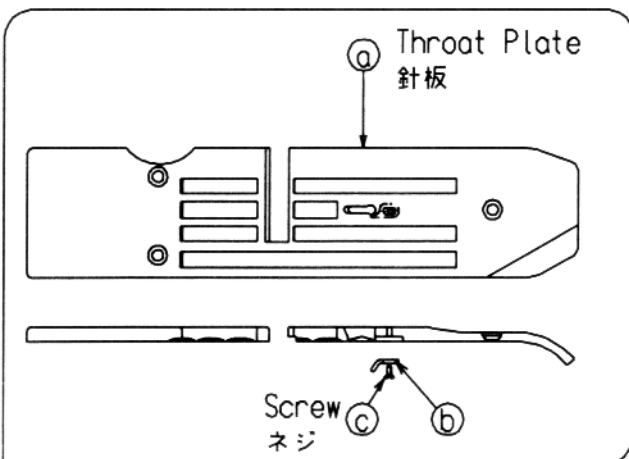

Fig.16

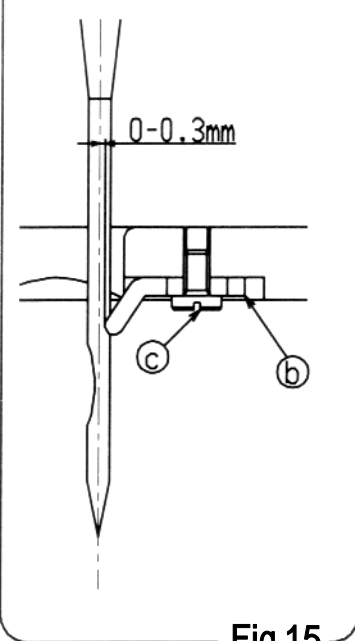

Fig.15

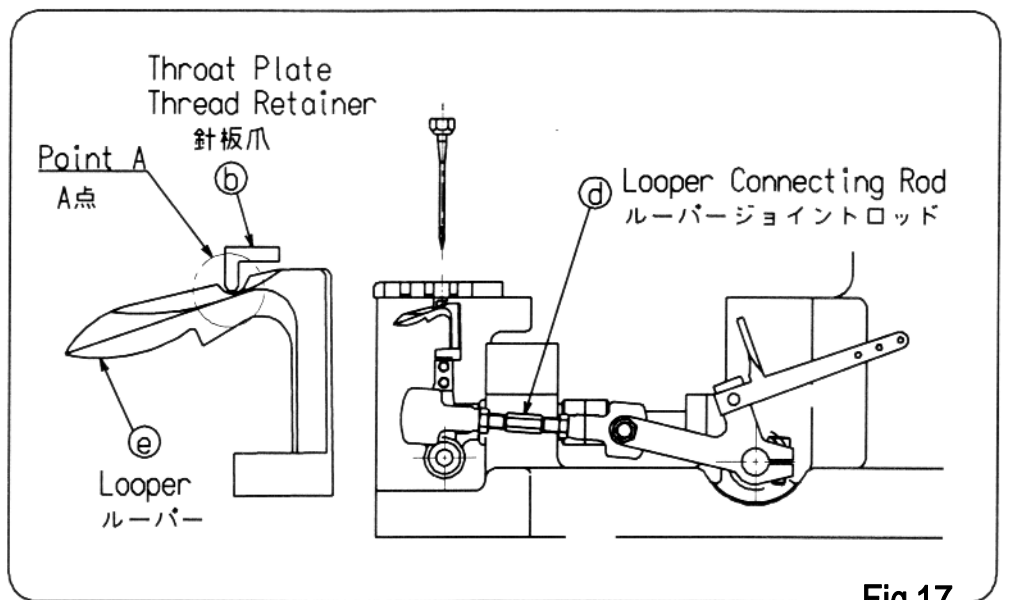

Fig.17

6. Troubleshooting

Problem	Cause	Solution	Ref.
Needle (looper) thread breaks	<ol style="list-style-type: none"> 1. Damaged looper 2. Too much thread tension 3. Too little thread tension 4. Thread snarled or hung up along path between thread stand and needle/looper 5. Incorrect threading. Thread not between tension discs 6. incorrect needle setting 7. Bent or damaged needle 8. Double sewing 9. Decreased stitch length because of worn feed dog teeth 	Replace Decrease Increase Correct Thread correctly Set correctly Replace Move up thread controller Replace feed dog	5-3 5-1 5-1 3 3 5-3-b 5-3-b 5-1 5-4-b
No chain formed between bags	<ol style="list-style-type: none"> 1. Incorrect threading 2. Too much looper thread tension 3. Too little needle thread tension 4. Thread controller too low 5. Needle and looper not timed each other 6. Not enough presser foot pressure 7. Thread is cut by feed dog teeth 8. Thread is feedback because feed dog is set too high 	Thread correctly Decrease Increase Move it up Adjust timing Increase File the row of feed dog teeth that comes in touch with thread Adjust height of feed dog	3 5-1 5-1 5-1 5-3-c 5-2 5-4 5-4-b
Skipping stitches	<ol style="list-style-type: none"> 1. Wrong setting of needle 2. Bent or damaged needle 3. Thread controller too low 4. Worn looper point 5. Needle too high 6. Thread sticking to needle due to heat 7. Needle guard pushing needle 8. Looper thread too loose to form a good triangle (reverse skip) 9. Needle and looper wide apart (scoop skip) 	Set correctly Replace Move it up Replace looper Lower needle bar Dampen needle thread with oil Adjust needle guard Increase looper thread tension Adjust distance needle to looper	5-3-b 5-3-b 5-1 5-3-c 5-3-b * 5-4-d 5-1 5-3-c
Needle or looper breaks	<ol style="list-style-type: none"> 1. Bent needle 2. Looper point hitting needle. Needle point hitting looper 3. Needle guard pushing needle or they are wide apart 	Replace Adjust timing of needle and looper Adjust needle guard	5-3-b 5-3-c 5-4-d
Stitch length not uniform, Curved seam	<ol style="list-style-type: none"> 1. Not enough presser foot pressure 2. Worn feed dog teeth 3. Bent needle 	Increase Replace feed dog Replace	5-2 5-4-b 5-3-b
Thread bites into crepe tape	<ol style="list-style-type: none"> 1. Too much needle thread tension 	Decrease	5-1
Crepe tape creases	<ol style="list-style-type: none"> 1. Feed dog, rear, is higher than feed dog front a little 	Adjust height	5-4-b

* Plastic contents existent in bag material is melt by the heated needle and may stick to needle, etc., causing skipping stitches. When closing woven cloth bags, kraft paper bags inclusive of polyethylene coated layer, polyethylene and PVC bags, etc., dampen needle thread with oil to prevent sticking of plastic contents. Use silicone oil processed thread for packing rice and other food products.

6. ミシンのトラブルの原因と対処

トラブル内容	原因	対処	参照
上糸、下糸が切れる	<ol style="list-style-type: none"> 1. ルーパーに傷がある。 2. 上・下糸調子のテンションが強すぎる。 3. 上・下糸調子のテンションが極端に弱すぎる。 4. 糸立てから針・ルーパーまでの間で、糸がからまったり、もつれたりする。 5. 糸通しが間違っている。糸調子皿から糸がはずれている。 6. 針の取付け方が間違っている。 7. 針が曲がったり、傷がある。 8. 二度がけしている。 9. 送り金が摩耗して縫目幅がこまかくなる。 	<p>ルーパーを交換する。</p> <p>テンションを弱くする。</p> <p>テンションを強くする。</p> <p>糸がからまったり、もつれないよう注意する。</p> <p>糸通しを正しく通す。</p> <p>針を正しく取付ける。</p> <p>針を交換する。</p> <p>上糸調節を上げる。</p> <p>送り金を交換する。</p>	<p>5-3</p> <p>5-1</p> <p>5-1</p> <p>3</p> <p>3</p> <p>5-3-b</p> <p>5-3-b</p> <p>5-1</p> <p>5-4-b</p>
空縫いが出ない	<ol style="list-style-type: none"> 1. 糸通しが間違っている。 2. 下糸調子のテンションが強すぎる。 3. 下糸調子のテンションが弱すぎる。 4. 上糸調節が低すぎる。 5. 針とルーパーとのタイミングが合っていない。 6. 押工金の圧が弱い。 7. 送り金の歯で糸を切る。 8. 送り金が高くセットされていて糸を送り返す。 	<p>糸通しを正しく通す。</p> <p>テンションを弱くする。</p> <p>テンションを強くする。</p> <p>上糸調節を上げる。</p> <p>針とルーパーとのタイミングを調整する。</p> <p>押工金の圧を強くする。</p> <p>送り金の糸押え部をヤスリで落す。</p> <p>送り金の高さを調整する。</p>	<p>3</p> <p>5-1</p> <p>5-1</p> <p>5-1</p> <p>5-3-c</p> <p>5-2</p> <p>5-4</p> <p>5-4-b</p>
目飛び	<ol style="list-style-type: none"> 1. 針の取付け方が間違っている。 2. 針が曲がったり、傷がある。 3. 上糸調節が低くセットしすぎている。 4. ルーパーの先端が摩滅している。 5. 針が高くセットされている。 6. 熱のため糸が針にくっつく。 7. 針ガイドが針を押ししている。 8. 下糸がゆるすぎてよい三角形をつくらない。(かえり目飛び) 9. 針とルーパーの間隔が広い。(すくい目飛び) 	<p>針を正しく取付ける。</p> <p>針を交換する。</p> <p>上糸調節を上げる。</p> <p>ルーパーを交換する。</p> <p>針棒を下げる。</p> <p>糸に油を使用する。</p> <p>針ガイドを調整する。</p> <p>下糸のテンションを強くする。</p> <p>針とルーパーの間隔を調整する。</p>	<p>5-3-b</p> <p>5-3-b</p> <p>5-1</p> <p>5-3-c</p> <p>5-3-b</p> <p>*</p> <p>5-4-d</p> <p>5-1</p> <p>5-3-c</p>
針が折れる ルーパーが折れる	<ol style="list-style-type: none"> 1. 針が曲がっている。 2. 針にルーパーの先端が当たっている。ルーパーに針先が当たっている。 3. 針ガイドで針を押ししているか、隙間がある。 	<p>針を交換する。</p> <p>針とルーパーとのタイミングを調整する。</p> <p>針ガイドを調整する。</p>	<p>5-3-b</p> <p>5-3-c</p> <p>5-4-d</p>
縫目巾が不揃い 縫目が曲がっている	<ol style="list-style-type: none"> 1. 押工金の圧が弱い。 2. 送り金の歯が摩滅している。 3. 針が曲がっている。 	<p>押工金の圧を強くする。</p> <p>送り金を交換する。</p> <p>針を交換する。</p>	<p>5-2</p> <p>5-4-b</p> <p>5-3-b</p>
クレープ紙に糸が くいこむ	<ol style="list-style-type: none"> 1. 上糸調子のテンションが強すぎる。 	<p>テンションを弱くする。</p>	<p>5-1</p>
クレープ紙にしわが できる	<ol style="list-style-type: none"> 1. 送り金後が送り金前より高くセットされている。 	<p>送り金後を正しくセットする。</p>	<p>5-4-b</p>

* 樹脂クロス袋や、クラフト紙袋にポリエチレンコーティングされている袋、ポリエチレン、塩化ビニール袋等を縫う時に、摩擦熱によって袋が溶けて針等にくっつき、目飛び等が発生し易い傾向がありますので、その場合には、上糸に油をつけたり、供米用、食品関係等にはシリコン加工糸をご使用ください。

ORDERING PARTS

1. Description of each part and its stamp number is described in this parts list. Screws and nuts for parts are shown adjacent to the relevant parts. When ordering parts, describe clearly stamp number with its name of part.
2. The parts which have no Ref. Number can not be delivered independently; always order it as an assembly.
3. A set of assembled parts is represented by the stamp number of its main parts.
4. The last figure on the parts stamp number advances on each improvement of the parts.
5. Parts No. described in [] of Remarks means old parts No.
 - The parts list is subject to change without prior notice.

ご注文上の注意事項

1. ご注文の際は、部品番号、部品名称、個数を明記ください。
2. 但し(図番 Ref.No.)の記入がない部品は、単体販売できませんので、それに該当する完備部品(組部品)をご注文ください。
3. 組部品はその中の主パーツの刻印番号で表示してあります。
4. 刻印番号は、その部品が改良される都度に、最後の数字が1番ずつ繰り上がり、新しい刻印番号にかわりますのでご了承ください。
5. 摘要欄中の[]内は旧パーツ番号です。
 - 本部品表は改良のため予告なく変更することがあります。

CONTENTS 目次

01.	MISCELLANEOUS COVERS PARTS	16
	カバー関係	
02-1.	THREAD TENSION & OILING PARTS	18
	糸調子、給油関係	
02-2.	THREAD TENSION & NEEDLE THREAD OILER (DS-9AW,DS-9CW)	20
	糸調子、上糸給油器関係	
03.	BUSHING PARTS	22
	軸受関係	
04.	NEEDLE BAR & CRANK SHAFT PARTS	24
	針棒、クランクシャフト関係	
05.	PRESSER FOOT PARTS	26
	押工金関係	
06.	LOOPER ROCKER & CONNECTING ROD PARTS	28
	ルーパー揺動関係	
07-1.	FEED DRIVING & THROAT PLATE PARTS (DS-9A, DS-9AW)	30
	送り機構、針板関係	
07-2.	FEED DRIVING & THROAT PLATE PARTS (DS-9C, DS-9P, DS-9CW)	32
	送り機構、針板関係	
08-1.	CUTTER PARTS (DS-9A, DS-9AW)	34
	カッター関係	
08-2.	CUTTER PARTS (DS-9C, DS-9CW)	36
	カッター関係	
09.	THREAD BREAK DETECTOR & BINDER PARTS	38
	糸切れ検出バインダー関係	
	LIST OF SCREW, NUT & WASHER	40, 41
	ネジ、ナット、ワッシャー一覧図	
	NUMERICAL INDEX OF PARTS	42-44
	パーツ索引	

01. MISCELLANEOUS COVERS PARTS カバー関係

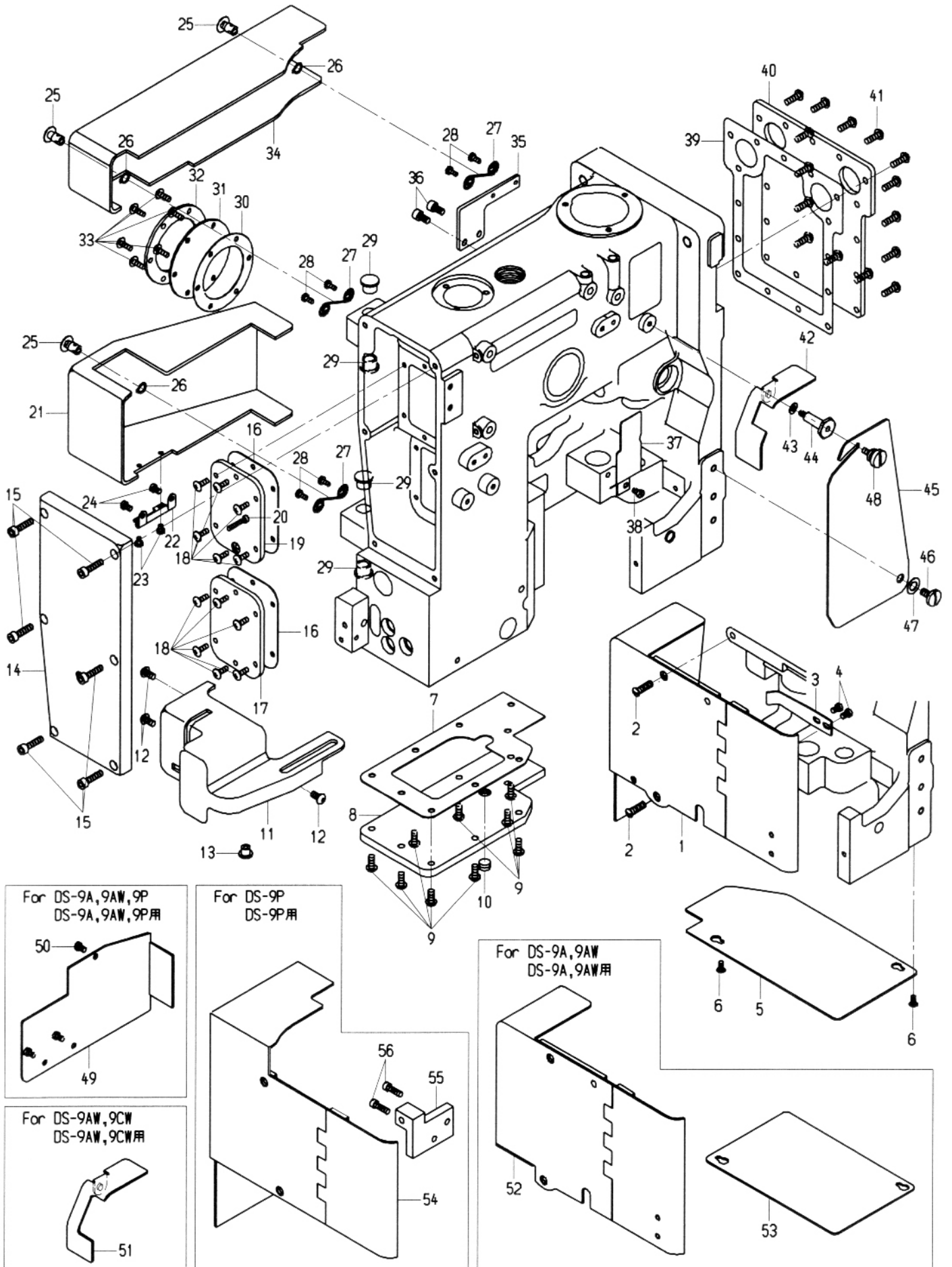

01. MISCELLANEOUS COVERS PARTS

カバー関係

図番 Ref.No.	部品番号 Part No.	部品名称 Description	個数 Q ty					摘要 Remarks	
			A	C	P	AW	CW		
1	105017B	Cloth Plate		1	-	-	-	1	
2	7/32S32007	Screw for 105017B		2	2	2	2	2	
3	065044	Cloth Plate Spring		1	1	1	1	1	
4	11/64S40005	Screw for 065044		2	2	2	2	2	
5	305151	Face Plate, lower		-	1	1	-	1	
6	3S4 x 8	Screw for 305151,305152		2	2	2	2	2	
7	305052	Gasket		1	1	1	1	1	
8	305042	Face Plate, upper		1	1	1	1	1	
9	3S5 x 12	Screw for 305042,305052		9	9	9	9	9	
10	11G1/8NPT	Plug		1	1	1	1	1	
11	305111	Needle Bar Cover		1	1	1	1	1	
12	3S5 x 10	Screw for 305111		3	3	3	3	3	
13	065401	Rubber Bushing		1	1	1	1	1	
14	305012	Body Head Cover		1	1	1	1	1	
15	4B5 x 20	Screw for 305012		6	6	6	6	6	
16	305091	Gasket		2	2	2	2	2	
17	305082	Top Cover B		1	1	1	1	1	
18	10S4 x 12K	Screw for 305081,305082,305091		12	12	12	12	12	
19	305081	Top Cover A		1	1	1	1	1	
20	SC63278	Screw		1	1	1	1	1	
21	305021	Cutter Cover		-	1	-	-	1	
22	E07001	Hinge(2FZ-11)		-	1	-	-	1	
23	9/64S40004	Screw for E07001		-	2	-	-	2	
24	11/64S40005	Screw for E07001		-	2	-	-	2	
25	E07002	Fastener Head(T8-149)		2	3	2	2	3	
26	1RS-8	Stop Ring(S-8)		2	3	2	2	3	
27	E07003	Fastener Spring(ST8)		2	3	2	2	3	
28	9/64S40004	Screw for E07003		4	6	4	4	6	
29	255351	Rubber Bushing		3	-	3	3	-	
30	305141	Gasket		1	1	1	1	1	
31	035191	Side Cover		1	1	1	1	1	
32	035201	Side Cover Retainer		1	1	1	1	1	
33	10S4 x 12K	Screw for 035201,035191,305141		6	6	6	6	6	
34	305031	Cylinder Cover		1	1	1	1	1	
35	305122	Fastener Spring Base		1	1	1	1	1	
36	4B5 x 10	Screw for 305122		2	2	2	2	2	
37	305261	Looper Thread Cover		1	1	1	1	1	
38	11/64S40005	Screw for 305261		1	1	1	1	1	
39	305072	Gasket		1	1	1	1	1	
40	305062	Inside Cover		1	1	1	1	1	
41	3S5 x 15	Screw for 305062,305072		15	15	15	15	15	
42	305241	Looper Thread Take-Up Cover B		1	1	1	-	-	
43	11/64W10101	Washer		1	1	1	1	1	
44	305171	Post		1	1	1	1	1	
45	305162	Looper Thread Take-Up Cover A		1	1	1	1	1	
46	15/64S28017	Screw for 305162		1	1	1	1	1	
47	5/16W05201	Washer for 305162		1	1	1	1	1	
48	3/16S32004	Screw for 305162		1	1	1	1	1	
49	305271	Side Cover		1	-	1	1	-	
50	11/64S40005	Screw		3	-	3	3	-	
51	305242	Looper Thread Take-Up Cover B		-	-	-	1	1	
52	305281	Cloth Plate		1	-	-	1	-	
53	305152	Face Plate, lower		1	-	-	1	-	
54	305211	Cloth Plate		-	-	1	-	-	
55	305201	Cloth Plate Base		-	-	1	-	-	
56	3/16S28018	Screw for 305201		-	-	2	-	-	

02 1. THREAD TENSION & OILING PARTS

糸調子、給油関係

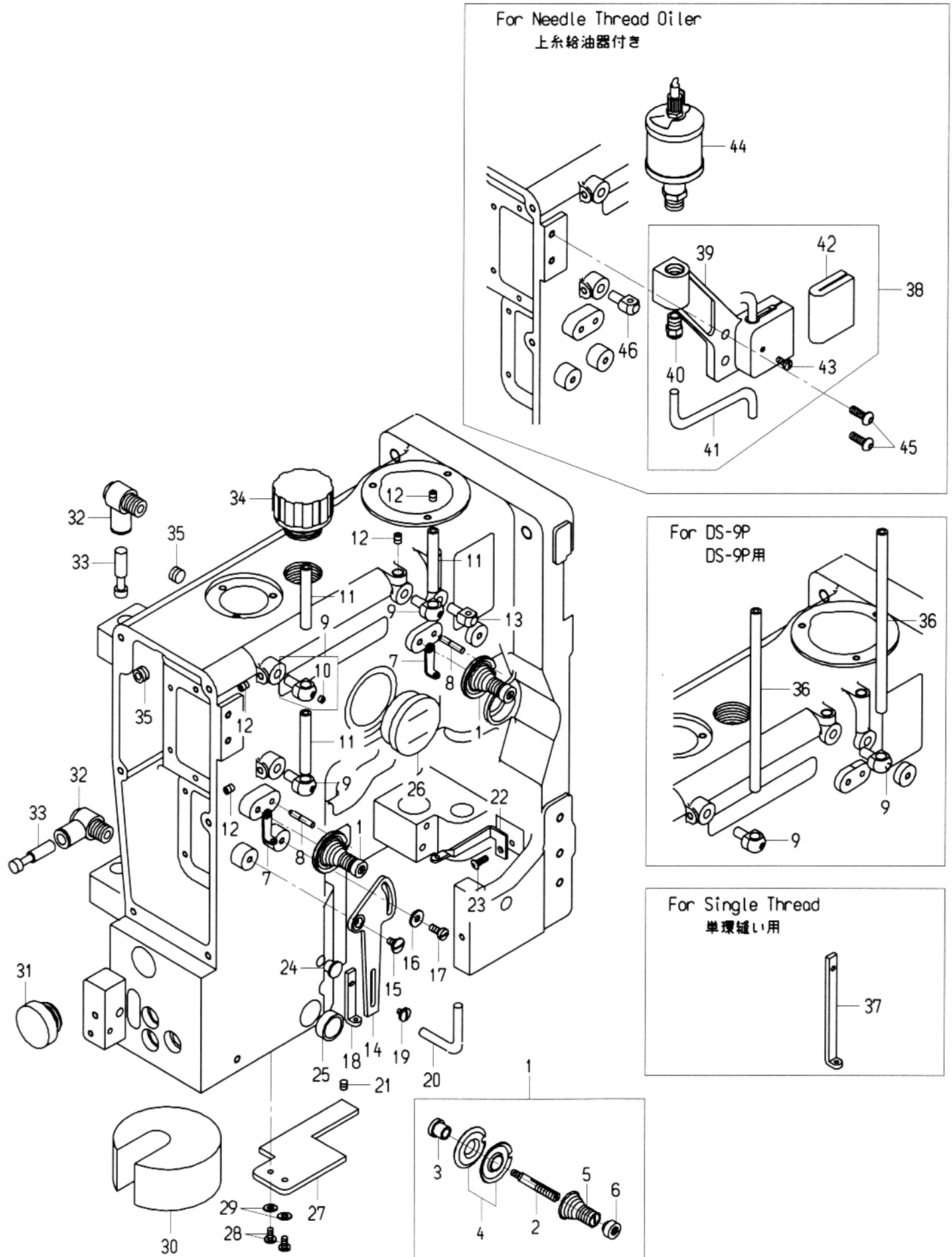

02 1. THREAD TENSION & OILING PARTS

糸調子、給油関係

図番 Ref.No.	部品番号 Part No.	部品名称 Description	個数 Q ty					摘要 Remarks	
			A	C	P	AW	CW		
1	065151E	Thread Tension Ass y	糸調子 組	2	2	2	-	-	(2-6)
2	065151	Tension Post	糸調子芯棒	2	2	2	-	-	
3	HA1348	Tension Post Ferrule	糸調子スリーブ	2	2	2	-	-	
4	80676A	Tension Disc	糸調子皿	4	4	4	-	-	
5	065181	Tension Spring	糸調子スプリング	2	2	2	-	-	
6	065171	Tension Nut	糸調子ナット	2	2	2	-	-	
7	245071	Thread Guide	糸ガイド	2	2	2	-	-	
8	80667	Tension Disc Stop Pin	糸調子皿止め	2	2	2	-	-	
9	075081	Frame Thread Eyelet Support	糸ガイド	3	3	3	-	-	(10)
10	11/64S40501	Screw for 075091	ネジ	3	3	3	-	-	
11	075091	Frame Thread Eyelet	糸ガイドパイプ	3	3	1	-	-	
12	1S5 x 6	Screw	ネジ	4	4	4	-	-	
13	065211	Frame Thread Eyelet	糸ガイド	1	1	1	-	-	
14	035031	Needle Thread Controller A	上糸調節 A	1	1	1	-	-	
15	11/64S40014	Screw for 035031	ネジ	1	1	1	-	-	
16	11/64W15103	Washer for 035031	ワッシャー	1	1	1	-	-	
17	11/64S40009	Screw for 035031	ネジ	1	1	1	-	-	
18	035042	Needle Thread Controller B	上糸調節 B	1	1	1	-	-	
19	9/64S40011	Screw for 035042	ネジ	1	1	1	-	-	
20	305131	Needle Thread Guide	上糸掛ケ	1	1	1	-	-	
21	1S5 x 5	Screw for 305131	ネジ	1	1	1	-	-	
22	255262	Looper Thread Guide	下糸ガイド	1	1	1	-	-	
23	3S4 x 10	Screw for 255262	ネジ	1	1	1	-	-	
24	065401	Rubber Bushing	キャップ	1	1	1	1	1	
25	D05003	Oil Gauge (OLG 207R)	オイルゲージ	1	1	1	1	1	
26	D05007	Oil Gauge (KDM-40)	オイルゲージ	1	1	1	1	1	
27	305231	Felt	給油綿	1	1	1	1	1	
28	4S4 x 8	Screw for 305231	ネジ	2	2	2	2	2	
29	2W4	Washer	ワッシャー	2	2	2	2	2	
30	035821	Fence	フェンス	1	1	1	1	1	
31	D09002	Rubber Bushing (EZ3020AO)	給油口蓋	1	1	1	1	1	
32	D07055	Tube Fitting, elbow (POL8-02)	ユニバーサルエルボ	2	2	2	2	2	
33	D07056	Tube Fitting, plug (PP8)	プラグ	2	2	2	2	2	
34	D09005	Plug (BM-3/4)	給油口蓋	1	1	1	1	1	
35	11G1/8NPT	Plug	プラグ	2	2	2	2	2	
36	305291	Frame Thread Eyelet	糸ガイドパイプ	-	-	2	-	-	
37	305251	Needle Thread Controller	上糸調節	(1)	(1)	(1)	-	-	
		Needle Thread Oiler	上糸給油器付						
38	255392A	Needle Thread Oiler Ass y	上糸給油器 組	(1)	(1)	(1)	-	-	(39-43)
39	255392	Needle Thread Oiler Base	上糸給油器土台	(1)	(1)	(1)	-	-	
40	D07057	Tube Fitting, straight (PC4-01M)	ワンタッチ継手	(1)	(1)	(1)	-	-	
41	8FU2-4 x 130	Oil Tube	給油パイプ	(1)	(1)	(1)	-	-	
42	105521	Felt	給油綿	(1)	(1)	(1)	-	-	
43	9/64S40005	Screw	ネジ	(1)	(1)	(1)	-	-	
44	D03002	Oiler (38-1/4PF)	オイルー	(1)	(1)	(1)	-	-	
45	3S5 x 15	Screw for 255392	ネジ	(2)	(2)	(2)	-	-	
46	065211	Frame Thread Eyelet	糸ガイド	(1)	(1)	(1)	-	-	

02 2. THREAD TENSION & NEEDLE THREAD OILER (DS 9AW,DS 9CW) 糸調子、上糸給油器関係

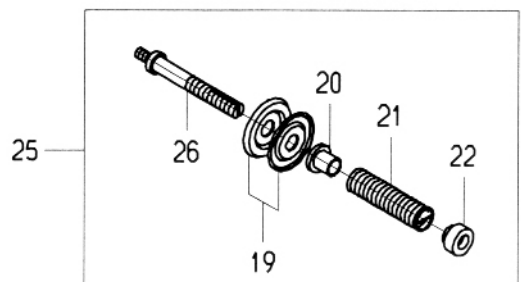
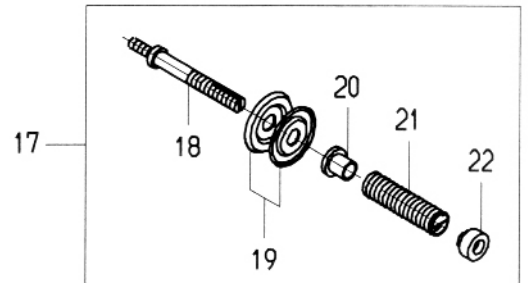
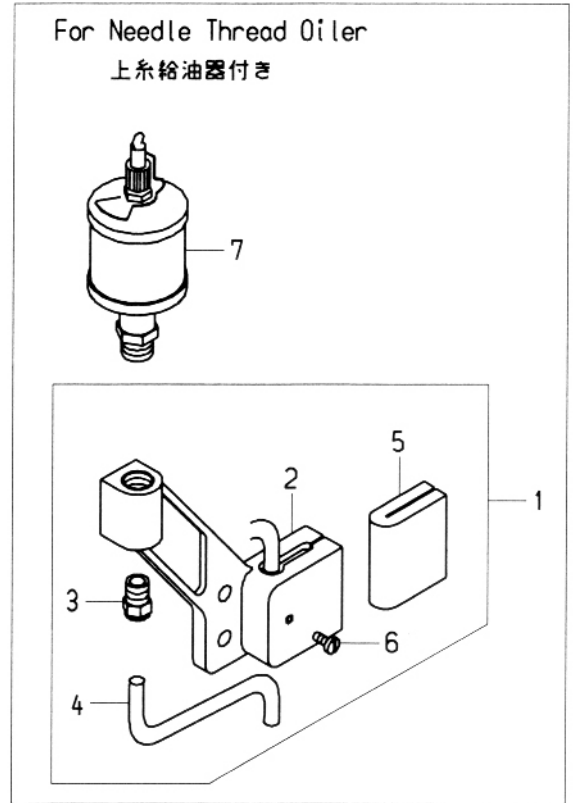
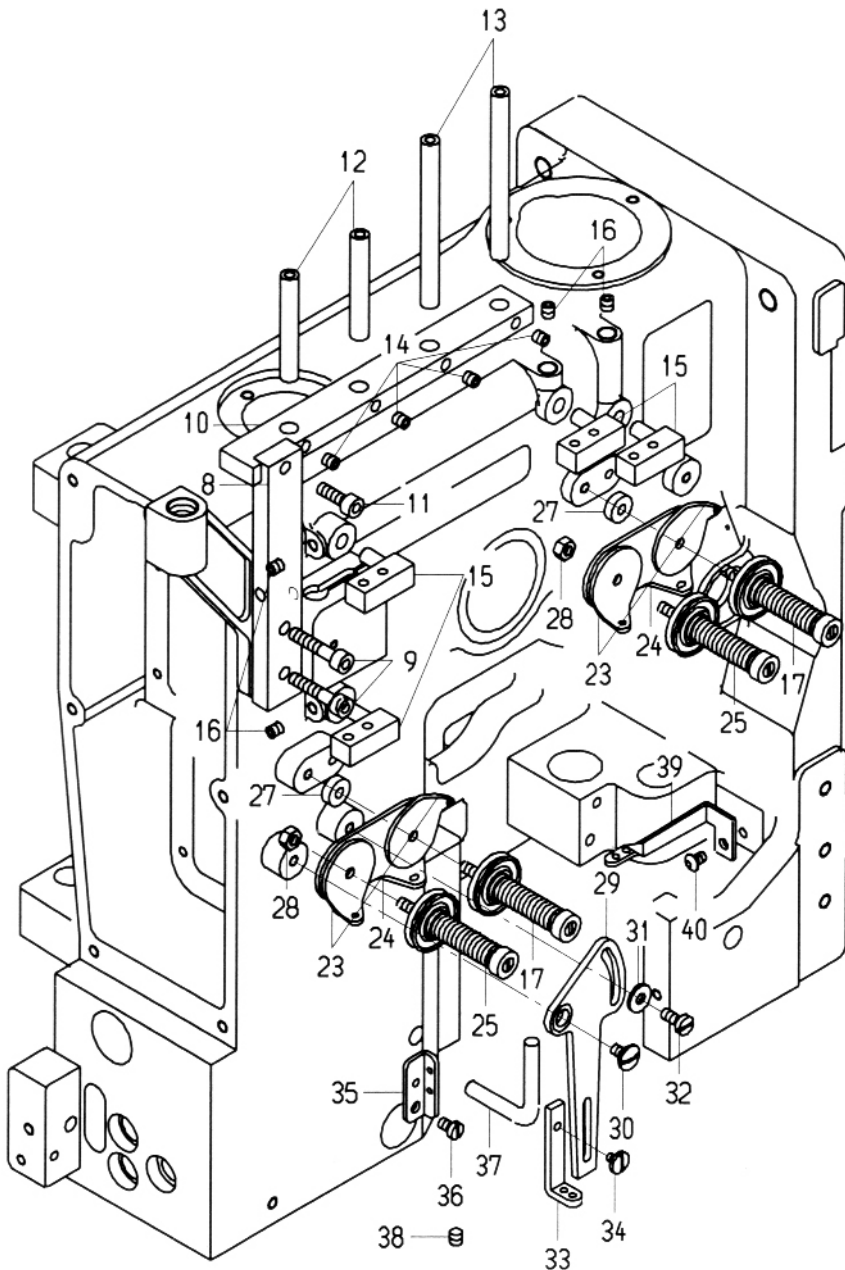

02 2. THREAD TENSION & NEEDLE THREAD OILER (DS 9AW,DS 9CW)

糸調子、上糸給油器関係

図番 Ref.No.	部品番号 Part No.	部品名称 Description	個数 Q ty		摘要 Remarks
			9AW	9CW	
1	305401A	Needle Thread Oiler Ass y	1	1	(2-6)
2	305401	Needle Thread Oiler	1	1	
3	D07057	Tube Fitting, straight(PC4-01M)	1	1	
4	8FU2-4 × 130	Oile Tube	1	1	
5	105521	Felt	1	1	
6	9/64S40005	Screw	1	1	
7	D03002	Oile(38-1/4PF)	1	1	
8	305371	Thread Guide Holder Base	1	1	
9	4B5 × 25	Screw	2	2	
10	305361	Thread Guide Holder	1	1	
11	4B5 × 15	Screw	1	1	
12	075091	Frame Thread Eyelet	2	2	
13	305441	Frame Thread Eyelet	2	2	
14	1S5 × 5	Screw for 075091,305441	4	4	
15	105561	Thread Eyelet	4	4	(18-22)
16	1S5 × 5	Screw for 105561	4	4	
17	035021A	Thread Tension Ass y	2	2	
18	035021	Tension Post	2	2	
19	065261	Tension Disc	8	8	
20	035071	Tension Post Ferrule	4	4	
21	035061	Tension Spring	4	4	
22	065171	Tension Nut	4	4	
23	015011	Tension Thread Guide	4	4	
24	035011	Tension Thread Guide	2	2	
25	035022A	Thread Tension Ass y	2	2	(19-22,26)
26	035022	Tension Post	2	2	
27	305431	Collar	1	1	
28	11/64N40104	Nut	2	2	
29	035031	Needle Thread Controller A	1	1	
30	11/64S40014	Screw for 035031	1	1	
31	11/64W15103	Washer for 035031	1	1	
32	11/64S40009	Screw for 035031	1	1	
33	035043	Needle Thread Controller B	1	1	
34	9/64S40011	Screw for 035043	1	1	
35	305381	Needle Thread Guide	1	1	
36	11/64S40006	Screw for 305381	1	1	
37	305131	Needle Thread Guide	1	1	
38	1S5 × 5	Screw for 305131	1	1	
39	305391	Looper Thread Guide	1	1	
40	3S4 × 10	Screw for 305391	1	1	

03. BUSHING PARTS 軸受関係

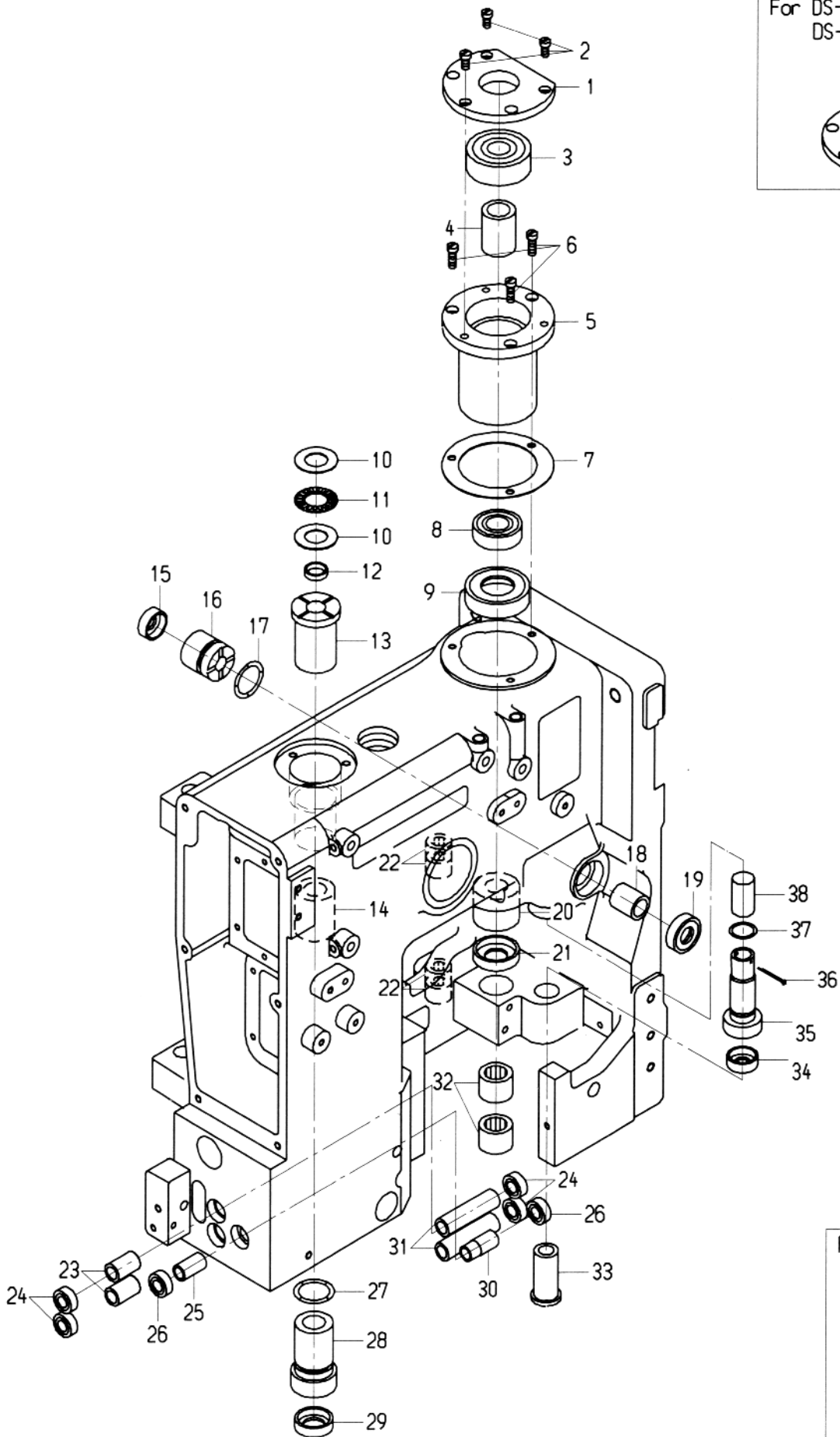

For DS-9P, Special Order
DS-9P, 特注部品

39

For DS-9AW, 9CW
DS-9AW, 9CW用

40

03. BUSHING PARTS 軸受関係

図番 Ref.No.	部品番号 Part No.	部品名称 Description	個数 Q ty					摘要 Remarks	
			A	C	P	AW	CW		
1	031091	Bearing Holder	ベアリング押工	1	1	-	1	1	
2	3/16S28014	Screw for 031091	ネジ	3	3	3	3	3	
3	1A01002	Ball Bearing (6302ZZ)	ボールベアリング	1	1	1	1	1	
4	031111	Collar A	カラーA	1	1	1	1	1	
5	031082	Crank Shaft Bushing Housing	ベアリングケース	1	1	1	1	1	
6	3/16S28005	Screw for 031082	ネジ	3	3	3	3	3	
7	301041	Gasket	ガスケット	1	1	1	1	1	
8	1A01004	Ball Bearing (6202ZZ)	ボールベアリング	1	1	1	1	1	
9	D04003	Oil Seal (SC224211)	オイルシール	1	1	1	1	1	
10	4A01002	Thrust Washer (FTRA-1528)	スラストワッシャー	2	2	2	2	2	
11	4A01001	Thrust Bearing (FTNA-1528)	スラストベアリング	1	1	1	1	1	
12	302061	Ring, pilot	リング	1	1	1	1	1	
13	302052	Arm Rocker Shaft Bushing, rear	上後ブッシュ	1	1	1	1	1	
14	302041	Arm Rocker Shaft Bushing, middle	上中ブッシュ	1	1	1	1	1	
15	D04011	Oil Seal (TC10207)	オイルシール	1	1	1	1	1	
16	303041	Looper Drive Lever Shaft Bushing, rear	ベルクランク軸ブッシュ後	1	1	1	1	1	
17	31LP21	"O" Ring (P21)	"O" リング	1	1	1	1	1	
18	303031	Looper Drive Lever Shaft Bushing, front	ベルクランク軸ブッシュ前	1	1	1	1	1	
19	D04012	Oil Seal (TC12257)	オイルシール	1	1	1	1	1	
20	301031	Crank Shaft Bushing, middle	下中ブッシュ	1	1	1	1	1	
21	D04013	Oil Seal (TC15307)	オイルシール	1	1	1	1	1	
22	3A03016	Needle Bearing (HMK1012L)	ニードルベアリング	4	4	4	4	4	
23	112061	Presser Bar Bushing, upper	押工棒ブッシュ上	2	2	2	2	2	
24	D04016	Oil Seal (TC4 8.7 16.5 7)	オイルシール	4	4	4	4	4	
25	092052	Needle Bar Bushing, upper	針棒ブッシュ上	1	1	1	1	1	
26	D04015	Oil Seal (TC4 8 16.5 7)	オイルシール	2	2	2	2	2	
27	31LP21	"O" Ring (P21)	"O" リング	1	1	1	1	1	
28	302032	Arm Rocker Shaft Bushing, front	上前ブッシュ	1	1	1	1	1	
29	D04014	Oil Seal (SC15257)	オイルシール	1	1	1	1	1	
30	092062	Needle Bar Bushing, lower	針棒ブッシュ下	1	1	1	1	1	
31	062201	Presser Bar Bushing, lower	押工棒ブッシュ下	2	2	2	2	2	
32	3A03014	Needle Bearing (HMK1516LL)	ニードルベアリング	2	2	2	2	2	
33	303111	Looper Rocker Shaft Bushing, front	ルーパーシャフトブッシュ前	1	1	1	-	-	
34	D04011	Oil Seal (TC10207)	オイルシール	1	1	1	1	1	
35	303121	Looper Rocker Shaft Bushing, rear	ルーパーシャフトブッシュ後	1	1	1	1	1	
36	3P1.2 x 20	Split Pin	割りピン	1	1	1	1	1	
37	32LS14	"O" Ring (S14)	"O" リング	1	1	1	1	1	
38	707181	Filter	フィルター	1	1	1	1	1	
39	301091	Bearing Holder	ベアリング押工	(1)	(1)	1	(1)	(1)	
40	303112	Looper Rocker Shaft Bushing, front	ルーパーシャフトブッシュ前	-	-	-	1	1	

04. NEEDLE BAR & CRANK SHAFT PARTS 針棒、クランクシャフト関係

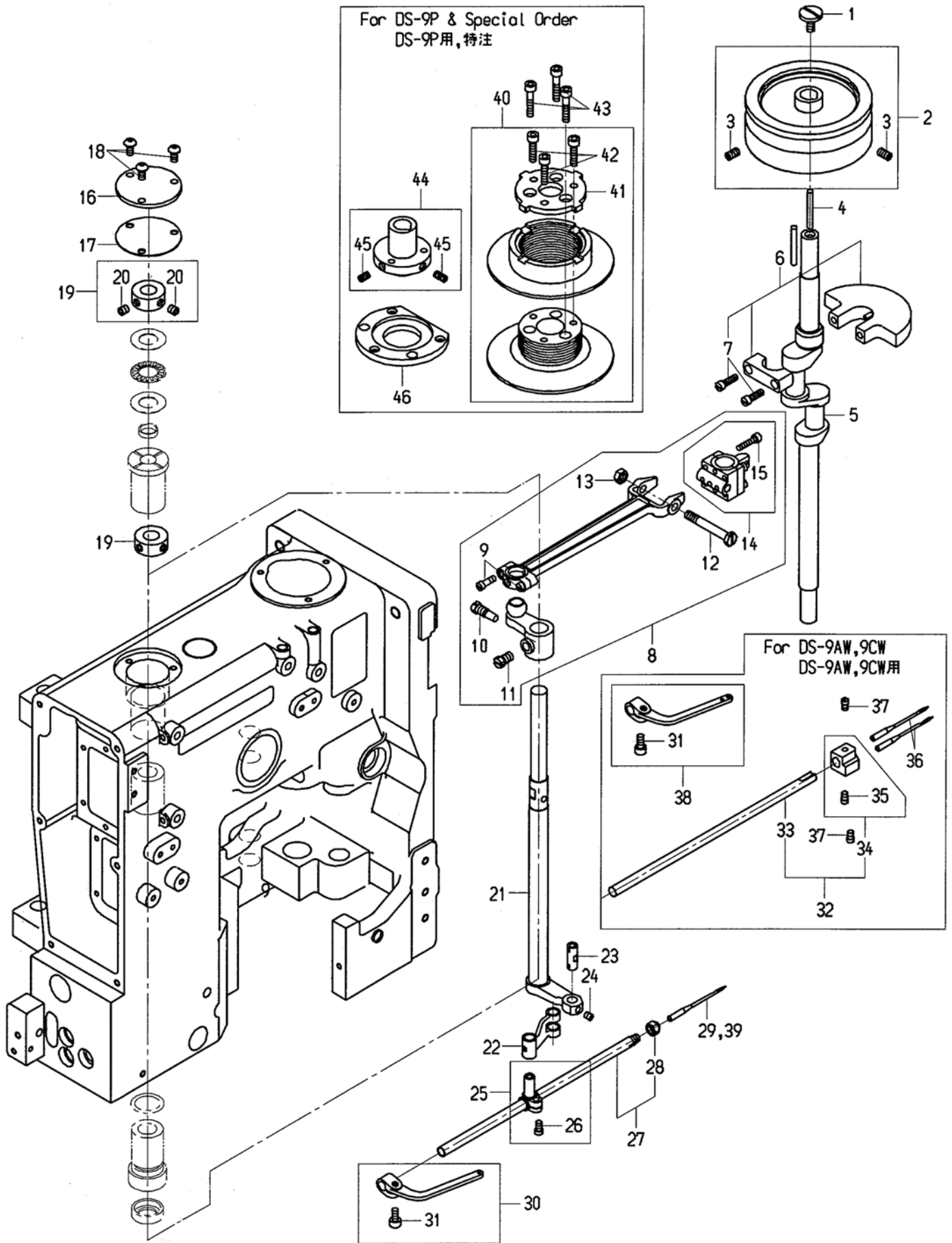

04. NEEDLE BAR & CRANK SHAFT PARTS

針棒、クランクシャフト関係

図番 Ref.No.	部品番号 Part No.	部品名称 Description	個数 Q ty					摘要 Remarks	
			A	C	P	AW	CW		
1	15/64S28012	Screw for 101101	ネジ	1	1	1	1	1	
2	301051	Pulley	プーリー	1	1	-	1	1	(3)
3	1S6 × 10	Screw for 101101	ネジ	2	2	-	2	2	
4	1K4 × 35S	Key (4 × 4 × 35)	キー(4 × 4 × 35)	1	1	1	1	1	
5	301021	Crank Shaft	クランクシャフト	1	1	1	1	1	
6	031131	Balance Weight	バランスウェイト	1	1	1	1	1	(7)
7	3/16S28018	Screw for 031131	ネジ	2	2	2	2	2	
8	032012A	Crank Shaft Connecting Rod Ass y	立ロッド 組	1	1	1	1	1	(9-14)
9	11/64S40090	Screw	ネジ	2	2	2	2	2	
10	9/32S28015	Spot Screw for 032012A	ネジ	1	1	1	1	1	
11	9/32S28001	Screw for 032012A	ネジ	1	1	1	1	1	
12	1/4S40010	Screw	ネジ	1	1	1	1	1	
13	1/4N40207	Nut	ナット	1	1	1	1	1	
14	032022	Crank Shaft Connection	立ロッドメタル	1	1	1	1	1	
15	4B4 × 20	Screw	ネジ	4	4	4	4	4	
16	302072	Rear Cover	後面板	1	1	1	1	1	
17	302082	Gasket	オイルシール	1	1	1	1	1	
18	3S5 × 10	Screw for 302072,302082	ネジ	3	3	3	3	3	
19	062052	Arm Rocker Shaft Collar	上シャフトカラー	2	2	2	2	2	(12)
20	15/64S28525	Screw for 062052	ネジ	4	4	4	4	4	
21	302011	Arm Rocker Shaft	上シャフト	1	1	1	1	1	
22	302021	Needle Bar Connecting Link	針棒クランク	1	1	1	1	1	
23	032141	Needle Bar Connecting Link Pin	針棒クランクピン	1	1	1	1	1	
24	1S5 × 6	Screw for 032141	ネジ	1	1	1	1	1	
25	032171	Needle Bar Connecting Stud	針棒抱キ	1	1	1	1	1	(25)
26	11/64S40002	Screw for 032171	ネジ	1	1	1	1	1	
27	302091A	Needle Bar Ass y	針棒 組	1	1	1	-	-	(27)
28	062151	Needle Clamp Nut	針棒ナット	1	1	1	-	-	
29	B20001	Needle (DR-H30 #26)	針	1	1	-	-	-	
30	302101	Needle Thread Take-Up	上糸天秤	1	1	1	-	-	(30)
31	4B5 × 10	Screw for 302101,302271	ネジ	1	1	1	1	1	
32	302251A	Needle Bar Ass y	針棒 組	-	-	-	1	1	(33,34)
33	302251	Needle Bar	針棒	-	-	-	1	1	
34	302261	Needle Holder	針ホルダー	-	-	-	1	1	(35)
35	11/64S40001	Screw	ネジ	-	-	-	1	1	
36	B20001	Needle (DR-H30 #26)	針	-	-	-	2	2	
37	11/64S40001	Screw	ネジ	-	-	-	2	2	
38	302271	Needle Thread Take-Up	上糸天秤	-	-	-	1	1	(30)
39	B05001	Needle (DR-G67 #27)	針	-	-	1	-	-	
40	301061A	Variable Diameter Pulley Ass y	バリダイヤプーリー 組	(1)	(1)	1	(1)	(1)	(41,42)
41	301081	Presser Plate	押工板	(1)	(1)	1	(1)	(1)	
42	4B5 × 20	Screw	ネジ	(3)	(3)	3	(3)	(3)	
43	SC10321	Screw	ネジ	(3)	(3)	3	(3)	(3)	
44	281122	Pulley Hub	プーリーハブ	(1)	(1)	1	(1)	(1)	(45)
45	SS142838	Screw	ネジ	(2)	(2)	2	(2)	(2)	
46	301091	Bearing Holder	ベアリング押工	(1)	(1)	1	(1)	(1)	

05. PRESSER FOOT PARTS 押工金関係

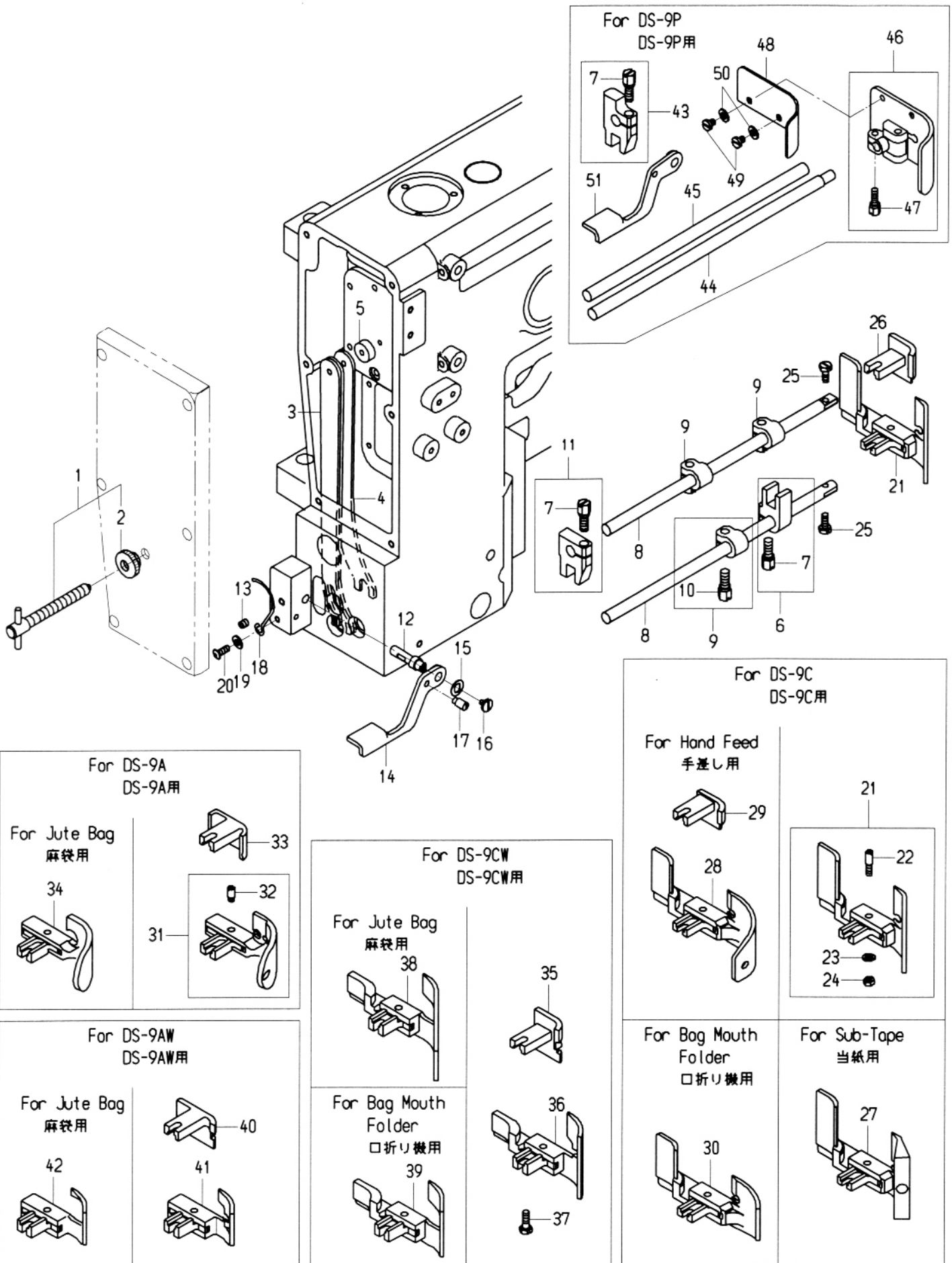

05. PRESSER FOOT PARTS

押工金関係

図番 Ref.No.	部品番号 Part No.	部品名称 Description	個数 Q ty					摘要 Remarks	
			A	C	P	AW	CW		
1	102171	Presser Spring Regulator Screw	板バネ調節ネジ	1	1	1	1	1	(2)
2	5/16N24301	Nut for 102171	ナット	1	1	1	1	1	
3	102091	Presser Bar Spring, large	板バネ (大)	2	2	3	2	2	
4	102101	Presser Bar Spring, small	板バネ (小)	2	2	-	2	2	
5	302121	Collar	間座	1	1	1	1	1	
6	102062	Presser Bar Lifting Bracket, left	押工棒抱キ (左)	1	1	1	1	1	(7)
7	15/64S28019	Screw for 102062	ネジ	2	2	2	2	2	
8	062181	Presser Bar	押工棒	2	2	-	2	2	
9	072121	Presser Bar Spring Adjuster	押工棒スプリング調節	3	3	3	3	3	(10)
10	15/64S28019	Screw for 072121	ネジ	3	3	3	3	3	
11	302222	Presser Bar Lifting Bracket	押工棒抱キ上	1	1	-	1	1	(7)
12	282121	Presser Bar Lifter Hinge Stud	押工揚ゲピン	1	1	1	1	1	
13	1S5 x 10	Screw for 282121	ネジ	1	1	1	1	1	
14	282242	Presser Bar Lifter	押工揚ゲ	1	1	-	1	1	
15	7/32W05201	Washer for 282242	ワッシャー	1	1	1	1	1	
16	9/64S40011	Screw for 282242	ネジ	1	1	1	1	1	
17	11/64S40043	Screw	ネジ	1	1	1	1	1	
18	305181	Spring	スプリング	1	1	1	1	1	
19	11/64W10101	Washer for 305181	ワッシャー	1	1	1	1	1	
20	3S4 x 10	Screw for 305181	ネジ	1	1	1	1	1	
21	102135A	Presser Foot Ass y, left	押工金 組 (左)	-	1	-	-	-	(22-24)
22	11/64S40073	Screw	ネジ	-	1	-	-	-	
23	3W5	Spring Washer	スプリングワッシャー	1	1	-	-	-	
24	11/64N40102	Nut	ナット	1	1	-	-	-	
25	11/64S40084	Screw for 102135A, 102162	ネジ	2	2	-	1	1	
26	102162	Presser Foot, right	押工金 (右)	-	1	-	-	-	
27	102136A	Presser Foot Ass y, left for sub-tape	押工金 組 (左) 当紙用	-	(1)	-	-	-	(22-24)
28	102134A	Presser Foot Ass y, left for hand feed	押工金 組 (左) 手差用	-	(1)	-	-	-	(22-24)
29	102161	Presser Foot, right for hand feed	押工金 (右) 手差用	-	(1)	-	-	-	
30	102321A	Presser Foot Ass y, left for bag mouth folder	押工金 組 (左) 口折り機用	-	(1)	-	-	-	(22-24)
31	062251A	Presser Foot Ass y, left	押工金 組 (左)	1	-	-	-	-	(32)
32	11/64S40064	Screw	ネジ	1	-	-	-	-	
33	062261	Presser Foot, right	押工金 (右)	1	-	-	-	-	
34	062252A	Presser Foot Ass y, left for jute bag	押工金 組 (左) 麻袋用	(1)	-	-	-	-	(32)
35	102261	Presser Foot, right	押工金 (右)	-	-	-	-	1	
36	102281A	Presser Foot Ass y, left	押工金 組 (左)	-	-	-	-	1	(22-24)
37	11/64S40100	Screw	ネジ	-	-	-	1	1	
38	102311A	Presser Foot Ass y, left for jute bag	押工金 組 (左) 麻袋用	-	-	-	-	(1)	(22-24)
39	102331A	Presser Foot Ass y, left for mouth folder	押工金 組 (左) 口折り機用	-	-	-	-	(1)	
40	062381	Presser Foot, right	押工金 (右)	-	-	-	1	-	
41	062391A	Presser Foot Ass y, left	押工金 組 (左)	-	-	-	1	-	(22-24)
42	062392A	Presser Foot Ass y, left for jute bag	押工金 組 (左) 麻袋用	-	-	-	(1)	-	(22-24)
43	302221	Presser Bar Right Lifting Bracket	押工棒抱キ (右)	-	-	1	-	-	(7)
44	302201	Presser Bar Left	押工棒 (左)	-	-	1	-	-	
45	302211	Presser Bar Right	押工棒 (右)	-	-	1	-	-	
46	302161A	Presser Foot Ass y	押工金 組	-	-	1	-	-	(47)
47	11/64S40018	Screw for 302161A	ネジ	-	-	1	-	-	
48	302191	Bag Guide	袋ガイド	-	-	1	-	-	
49	11/64S40045	Screw for 302191	ネジ	-	-	2	-	-	
50	11/64W10101	Washer for 302191	ワッシャー	-	-	2	-	-	
51	302231	Presser Bar Lifter	押工揚ゲ	-	-	1	-	-	

06. LOOPER ROCKER & CONNECTING ROD PARTS

ルーパー揺動関係

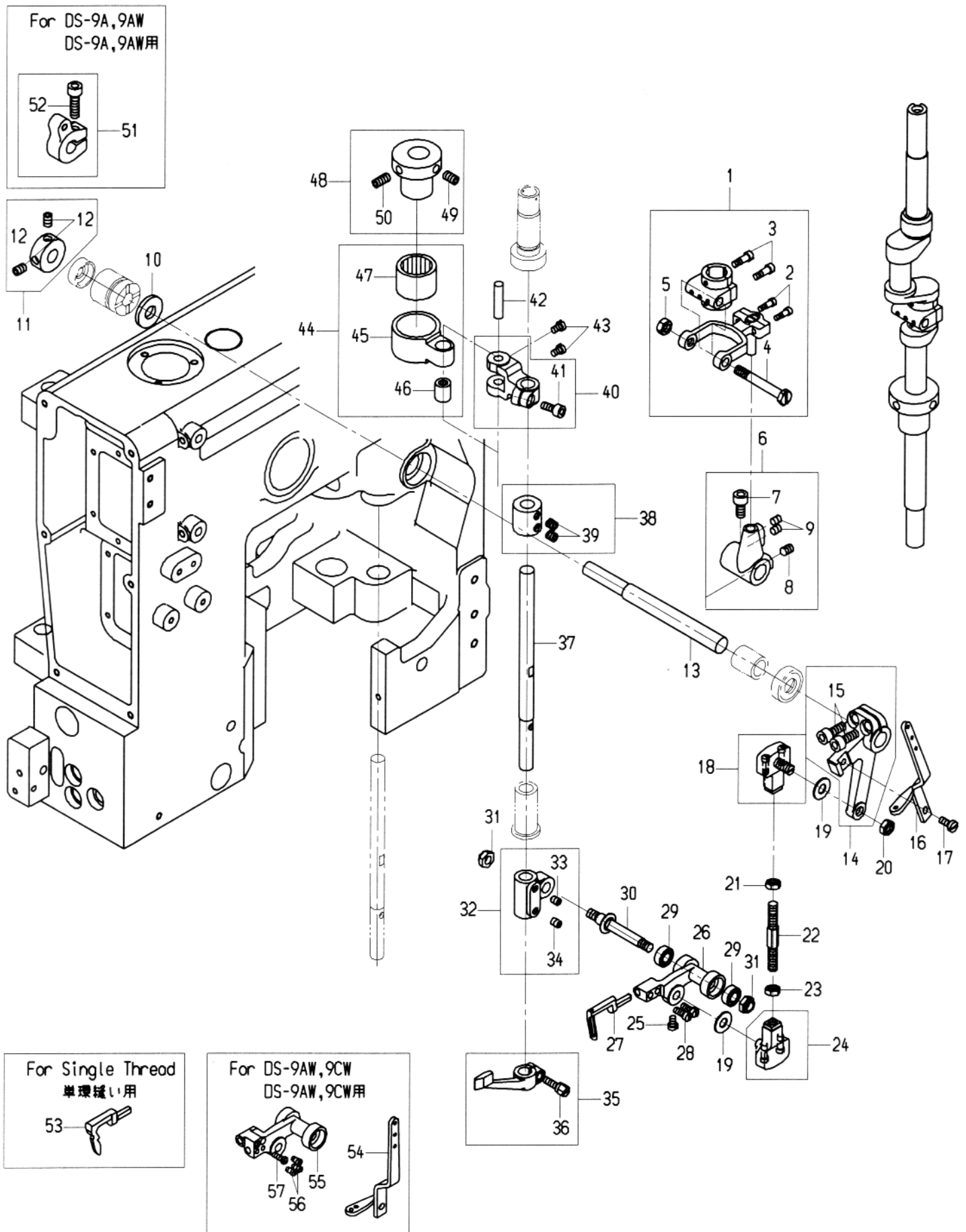

06. LOOPER ROCKER & CONNECTING ROD PARTS

ルーパー揺動関係

図番 Ref.No.	部品番号 Part No.	部品名称 Description	個数 Q ty					摘要 Remarks
			A	C	P	AW	CW	
1	033022A	Looper Bell Crank Connection Rod Ass y	1	1	1	1	1	(2-5)
2	9/64S40061	Screw	2	2	2	2	2	
3	11/64S40090	Screw	2	2	2	2	2	
4	1/4S40010	Screw	1	1	1	1	1	
5	1/4N40207	Nut	1	1	1	1	1	
6	303011	Looper Drive Lever Rocker	1	1	1	1	1	(7,8)
7	4B6 × 12	Screw for 303011	1	1	1	1	1	
8	1S6 × 8T	Screw for 303011	1	1	1	1	1	
9	1S5 × 6	Screw for 033022A	2	2	2	2	2	
10	303051	Thrust Collar	1	1	1	1	1	
11	304061	Set Collar	-	1	1	-	1	(12)
12	1S6 × 8	Screw for 304061	-	2	2	-	2	
13	303021	Looper Drive Lever Shaft	1	1	1	1	1	
14	303061	Looper Drive Lever	1	1	1	1	1	(15)
15	4B6 × 15	Screw for 303061	2	2	2	2	2	
16	033072	Looper Thread Take-Up	1	1	1	-	-	
17	11/64S40009	Screw for 033072	1	1	1	1	1	
18	063072AA	Looper Connecting Rod Ball Joint, right	1	1	1	1	1	
19	9/32W10106	Washer	2	2	2	2	2	
20	9/32N28210	Nut	1	1	1	1	1	
21	1/4N32201L	Nut	1	1	1	1	1	
22	303181	Looper Connecting Rod	1	1	1	1	1	
23	1/4N32201	Nut	1	1	1	1	1	
24	063092AA	Looper Connecting Rod Ball Joint, left	1	1	1	1	1	
25	11/64S40005	Screw for 063092AA	1	1	1	1	1	
26	303171	Looper Rocker	1	1	1	-	-	
27	033121	Looper	1	1	1	2	2	
28	11/64S40003	Screw for 033121	2	2	2	-	-	
29	1A01020	Ball Bearing (W687 ZZA)	2	2	2	2	2	
30	303161	Looper Rocker Cone Stud	1	1	1	1	1	
31	6N1/4	Nut	2	2	2	2	2	
32	303151	Looper Rocker Frame	1	1	1	1	1	
33	1S5 × 8T	Screw for 303151	1	1	1	1	1	
34	1S5 × 6	Screw for 303151	1	1	1	1	1	
35	103021	Looper Retainer	1	1	1	-	-	(36)
36	11/64S40018	Screw for 103021	1	1	1	-	-	
37	303131	Looper Rocker Shaft	1	1	1	1	1	
38	303141	Set Collar	1	1	1	1	1	(39)
39	1S6 × 6	Screw for 303141	2	2	2	2	2	
40	303091	Looper Rocker Shaft Arm	1	1	1	1	1	(41)
41	4B5 × 12	Screw for 303091	1	1	1	1	1	
42	303101	Link Pin	1	1	1	1	1	
43	11/64S40005	Screw for 303101	2	2	2	2	2	
44	303082A	Bearing Case Ass y	1	1	1	1	1	(45-47)
45	303082	Bearing Case	1	1	1	1	1	
46	3A03020	Bearing (SCE48P)	1	1	1	1	1	
47	3A03013	Bearing (HK2220LL)	1	1	1	1	1	
48	303072	Looper Avoid Eccentric	1	1	1	1	1	(49,50)
49	1S6 × 10	Screw for 303072	1	1	1	1	1	
50	1S6 × 12	Screw for 303072	1	1	1	1	1	
51	306072	Knife Lever A	1	-	-	1	-	(52)
52	4B6 × 20	Screw for 306072	1	-	-	1	-	
53	303191	Looper for Single Thread	(1)	(1)	(1)	-	-	
54	033301	Looper Thread Take-Up	-	-	-	1	1	
55	303211	Looper Rocker	-	-	-	1	1	
56	9/64S40066	Screw	-	-	-	3	3	
57	9/64S40003	Screw	-	-	-	1	1	

07 1. FEED DRIVING & THROAT PLATE PARTS (DS-9A,DS-9AW)

送り機構、針板関係

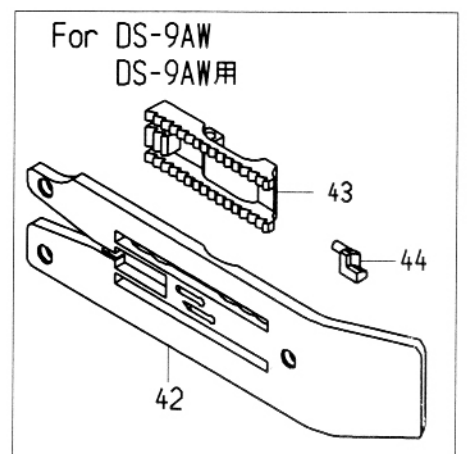
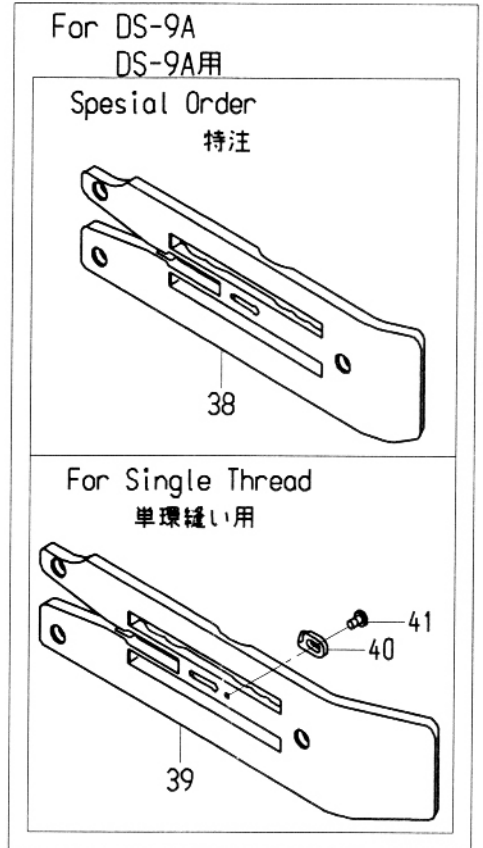
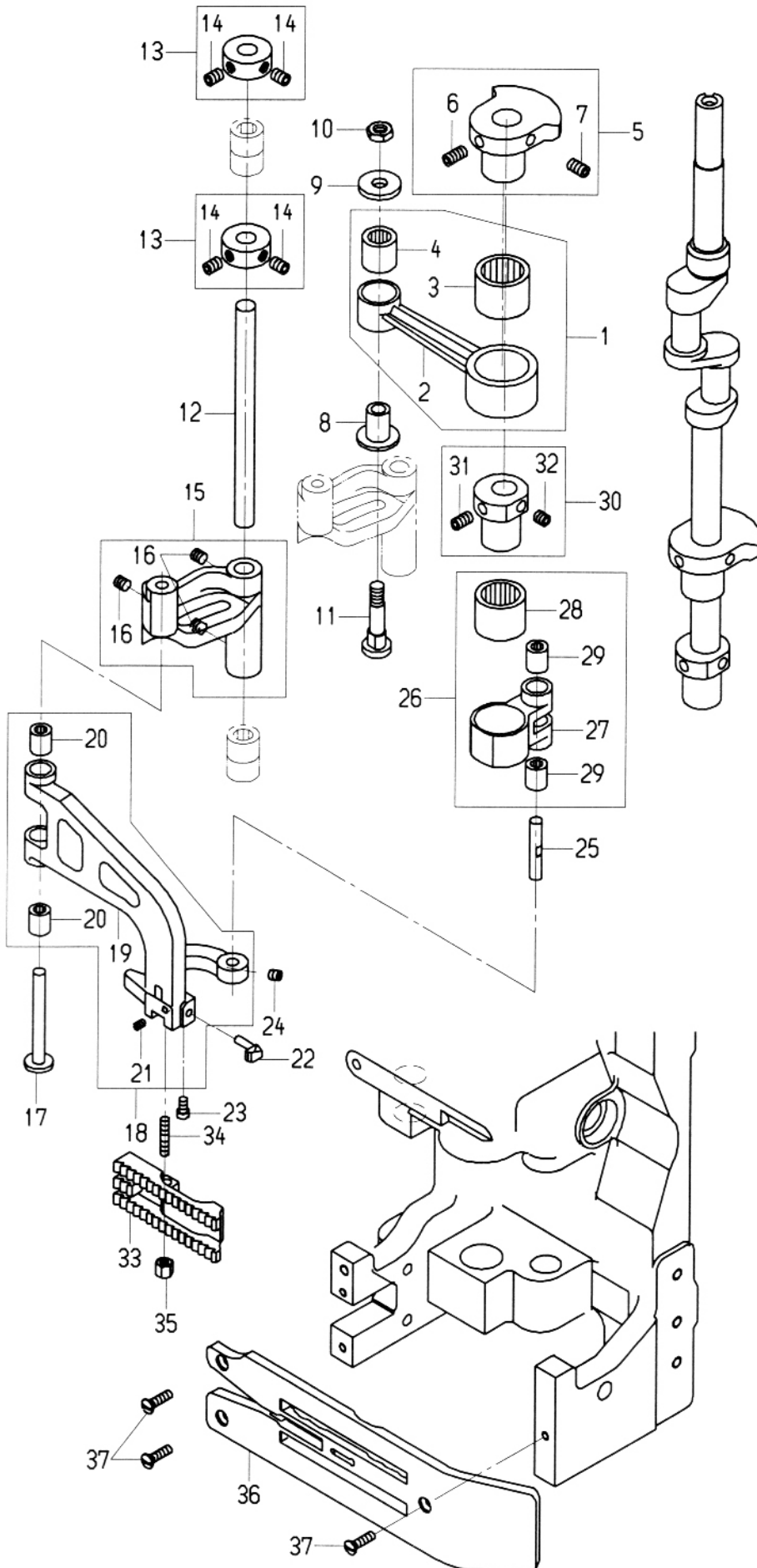

07 1. FEED DRIVING & THROAT PLATE PARTS (DS-9A,DS-9AW)

送り機構、針板関係

図番 Ref.No.	部品番号 Part No.	部品名称 Description	個数 Q ty		摘要 Remarks
			9A	9AW	
1	304021A	Feed Drive Eccentric Ass y	1	1	(2-4)
2	304021	Feed Rocker Eccentric Connection	1	1	
3	3A03013	Needle Bearing (HK2220LL)	1	1	
4	3A03018	Needle Bearing (HK1216LL)	1	1	
5	304011	Feed Rocker Eccentric	1	1	(6,7)
6	1S6 × 12	Screw for 304011	1	1	
7	1S6 × 10	Screw for 304011	1	1	
8	304041	Bushing	1	1	
9	181131	Washer	1	1	
10	9/32N28211	Nut	1	1	
11	304031	Feed Regulating Stud	1	1	
12	304051	Feed Rocker Shaft	1	1	
13	304061	Set Collar	2	2	(14)
14	1S6 × 8	Screw for 304061	4	4	
15	304201	Feed Rocker	1	1	(16)
16	1S6 × 6	Screw for 304201	3	3	
17	304261	Feed Bar Shaft	1	1	
18	304191A	Feed Bar Ass y	1	1	(19-21)
19	304191	Feed Bar	1	1	
20	3A03020	Needle Bearing (SCE48P)	2	2	
21	9/64S40502	Screw	1	1	
22	104033	Needle Guide	1	-	
23	11/64S40002	Screw for 104033	1	1	
24	1S5 × 5	Screw for 304091	1	1	
25	304091	Feed Crank Link Pin	1	1	
26	304082A	Feed Crank Link Ass y	1	1	(27-29)
27	304082	Feed Crank Link	1	1	
28	3A03019	Needle Bearing (HK2020LL)	1	1	
29	3A03020	Needle Bearing (SCE48P)	2	2	
30	304101	Feed Lift Eccentric	1	1	(31,32)
31	1S6 × 10	Screw for 304101	1	1	
32	1S6 × 6	Screw for 304101	1	1	
33	304211	Feed Dog	1	-	
34	11/64S40505	Screw for 304211	1	1	
35	11/64N40204	Nut for 304211	1	1	
36	304181	Throat Plate	1	-	
37	11/64S40074	Screw for 304181	3	3	
38	304182	Throat Plate	(1)	-	
39	304311	Throat Plate for Single Thread	(1)	-	
40	114131	Throat Plate Thread Retainer	(1)	-	
41	3/32S56004	Screw for 114131	(1)	-	
42	304281	Throat Plate	-	1	
43	304291	Feed Dog	-	1	
44	304301	Needle Guide	-	1	

07 2. FEED DRIVING & THROAT PLATE PARTS (DS-9C,DS-9P,DS-9CW)

送り機構、針板関係

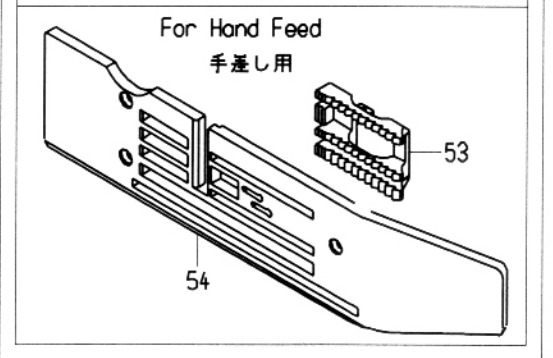
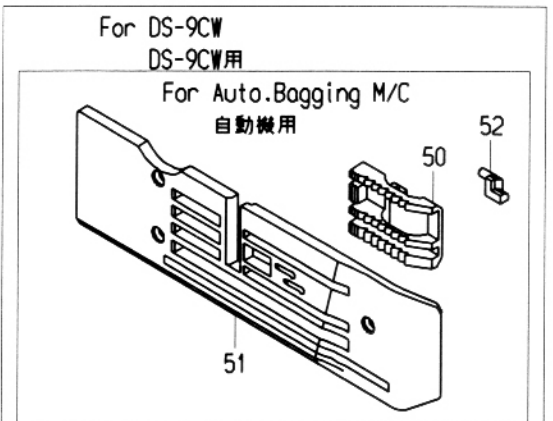
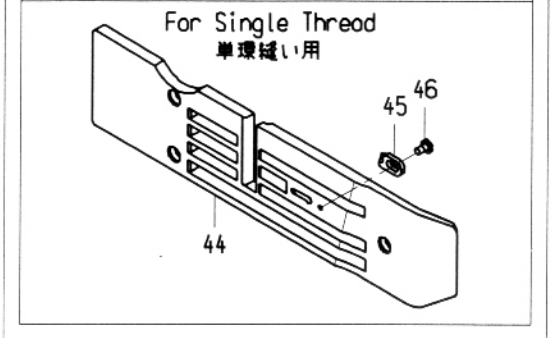
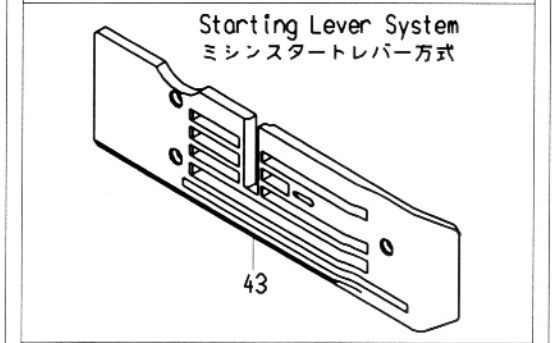
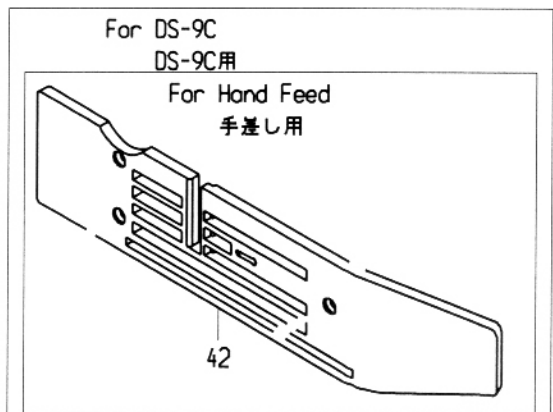
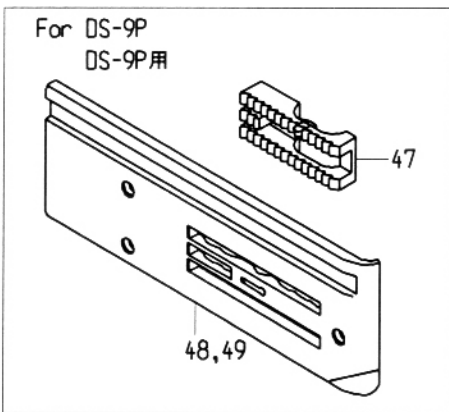
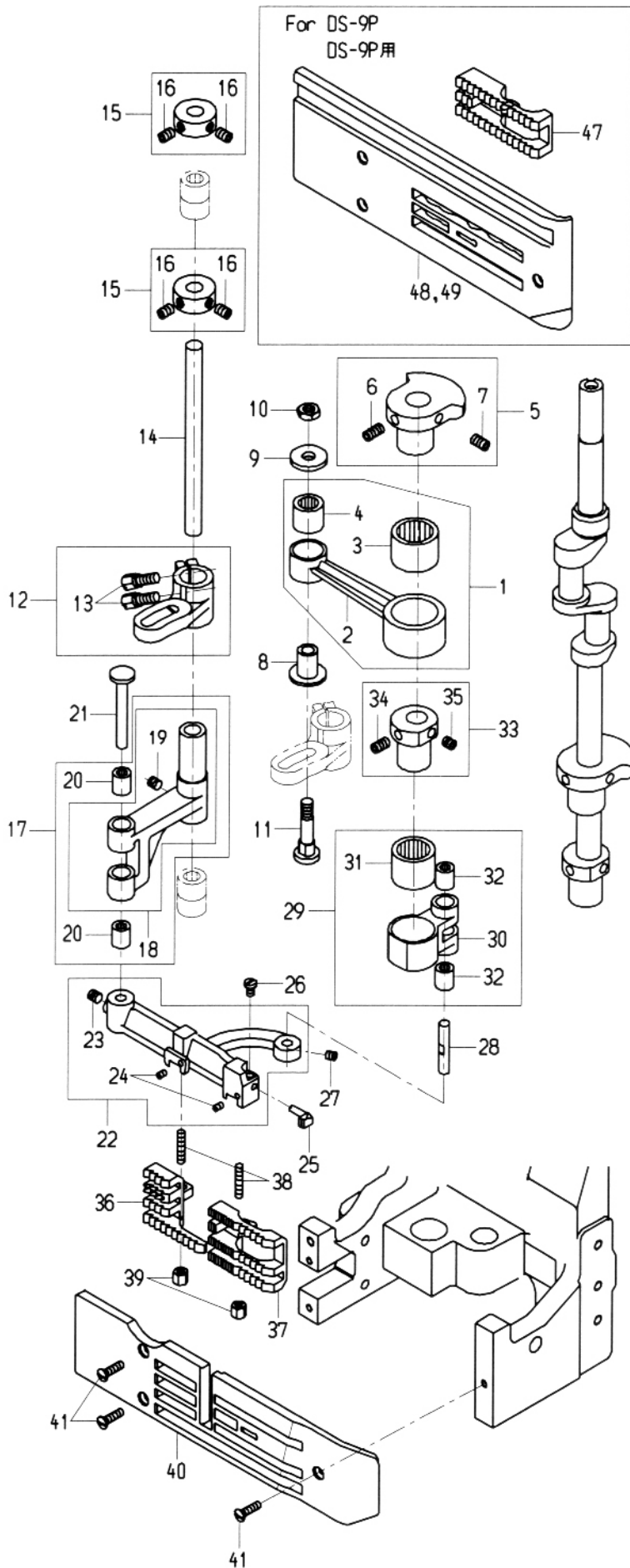

07 2. FEED DRIVING & THROAT PLATE PARTS (DS-9C,DS-9P,DS-9CW)

送り機構、針板関係

図番 Ref.No.	部品番号 Part No.	部品名称 Description	個数 Q ty			摘要 Remarks
			9C	9P	9CW	
1	304021A	Feed Drive Eccentric Ass y	1	1	1	(2-4)
2	304021	Feed Rocker Eccentric Connection	1	1	1	
3	3A03013	Needle Bearing (HK2220LL)	1	1	1	
4	3A03018	Needle Bearing (HK1216LL)	1	1	1	
5	304011	Feed Rocker Eccentric	1	1	1	(6,7)
6	1S6 × 12	Screw for 304011	1	1	1	
7	1S6 × 10	Screw for 304011	1	1	1	
8	304041	Bushing	1	1	1	
9	181131	Washer	1	1	1	
10	9/32N28211	Nut	1	1	1	
11	304031	Feed Regulating Stud	1	1	1	
12	064051	Feed Rocker Crank	1	1	1	(13)
13	15/64S28019	Screw for 064051	2	2	2	
14	304051	Feed Rocker Shaft	1	1	1	
15	304061	Set Collar	2	2	2	(16)
16	1S6 × 8	Screw for 304061	4	4	4	
17	304112A	Feed Rocker Ass y	1	1	1	(18-20)
18	304112	Feed Rocker	1	1	1	(19)
19	1S6 × 6	Screw for 304112	1	1	1	
20	3A03020	Needle Bearing (SCE48P)	2	2	2	
21	304251	Feed Bar Shaft	1	1	1	
22	304071	Feed Bar	1	1	1	(23,24)
23	1S6 × 6	Screw for 304071	1	1	1	
24	9/64S40502	Screw	2	2	2	
25	304121	Needle Guide	1	1	-	
26	11/64S40005	Screw for 304121	1	1	1	
27	1S5 × 5	Screw for 304091	1	1	1	
28	304091	Feed Crank Link Pin	1	1	1	
29	304082A	Feed Crank Link Ass y	1	1	1	(30-32)
30	304082	Feed Crank Link	1	1	1	
31	3A03019	Needle Bearing (HK2020LL)	1	1	1	
32	3A03020	Needle Bearing (SCE48P)	2	2	2	
33	304101	Feed Lift Eccentric	1	1	1	(34-35)
34	1S6 × 10	Screw for 304101	1	1	1	
35	1S6 × 6	Screw for 304101	1	1	1	
36	104072	Feed Dog, rear	1	-	1	
37	304131	Feed Dog, front	1	-	-	
38	11/64S40505	Screw for 104072, 304131	2	2	2	
39	11/64N40204	Nut for 104072, 304131	2	2	2	
40	104123	Throat Plate for automatic feed	1	-	-	
41	11/64S40074	Screw for 104123, 104093, 1040122	3	3	3	
42	104093	Throat Plate for Hand Feed	(1)	-	-	
43	104122	Throat Plate for automatic feed by lever start	(1)	-	-	
44	304171	Throat Plate for Single Thread	(1)	-	-	
45	114131	Throat Plate Thread Retainer	(1)	(1)	-	
46	3/32S56004	Screw for 114131	(1)	(1)	-	
47	304221	Feed Dog	-	1	-	
48	304231	Throat Plate	-	1	-	
49	304241	Throat Plate for Single Thread	-	(1)	-	
50	104231	Feed Dog, front	-	-	1	
51	104241	Throat Plate	-	-	1	
52	304301	Needle Guide	-	-	1	
53	104232	Feed Dog, front for Hand Feed	-	-	(1)	
54	104242	Throat Plate for Hand Feed	-	-	(1)	

08 1. CUTTER PARTS (DS-9A,DS-9AW) カッター関係

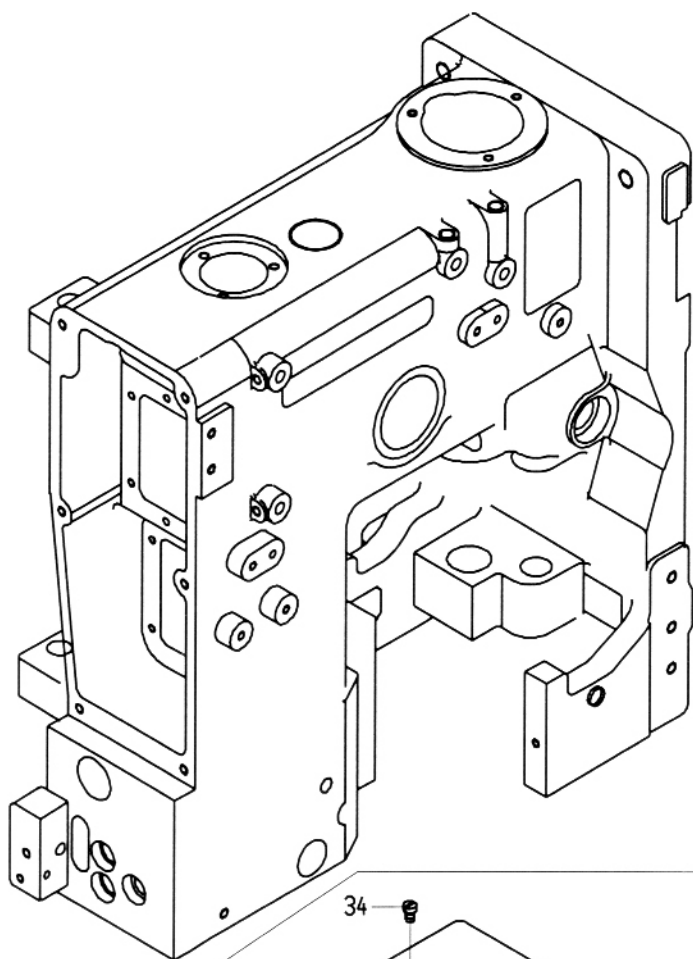

Special Order 特注
 Thread Pusher Set
 糸押え込みセット

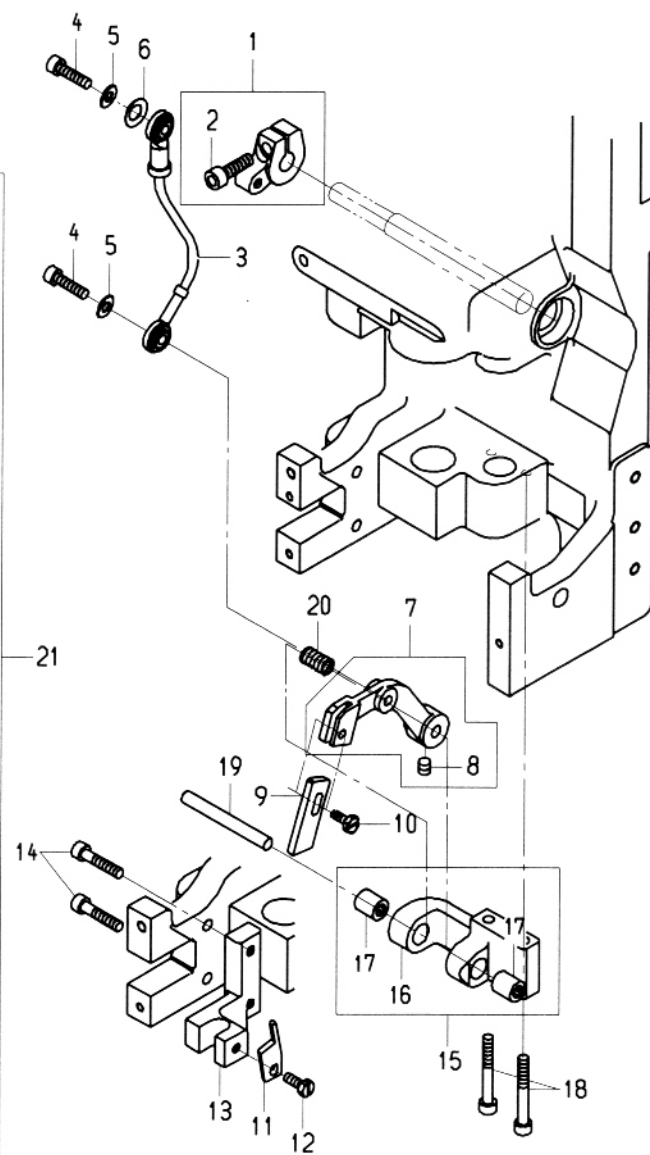
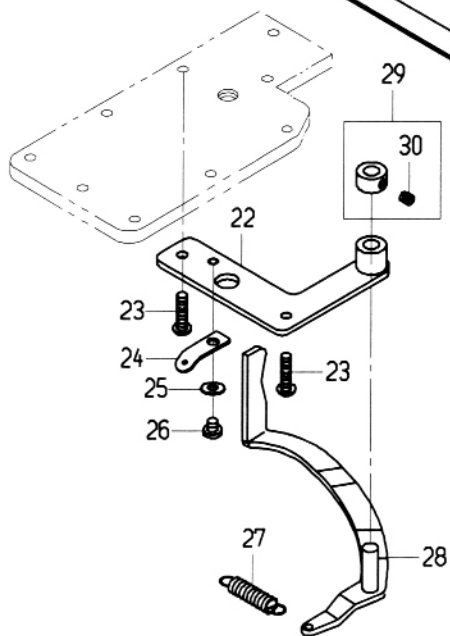
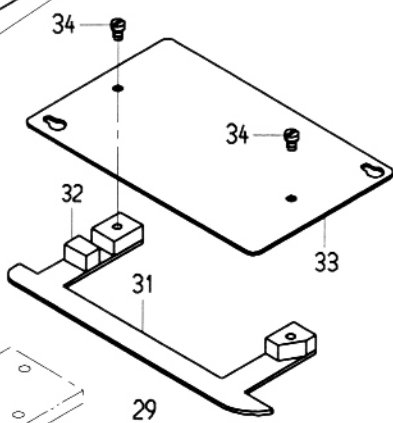

08 1. CUTTER PARTS (DS-9A,DS-9AW)

カッター関係

図番 Ref.No.	部品番号 Part No.	部品名称 Description	個数 Q ty		摘要 Remarks	
			9A	9AW		
1	306072	Knife Lever A	ナイフレバーA	1	1	(2)
2	4B6 × 20	Screw for 306072	ネジ	1	1	
3	306081	Ball Joint Rod	ボールジョイント	1	1	
4	4B5 × 20	Screw for 306081	ネジ	2	2	
5	2W5S	Washer	座金	2	2	
6	5/16W05201	Spring Washer	スプリングワッシャー	1	1	
7	306091	Knife Lever B	ナイフレバーB	1	1	(8)
8	15/64S28525	Screw	ネジ	1	1	
9	066143	Knife B	ナイフ B	1	1	
10	11/64S40084	Screw for 066143	ネジ	1	1	
11	066133	Knife A	ナイフ A	1	1	
12	3/16S28028	Screw for 066133	ネジ	1	1	
13	306131	Knife Base	固定刃土台	1	1	
14	4B5 × 25	Screw for 306131	ネジ	2	2	
15	306111A	Knife Lever Base Ass y	ナイフレバー土台 組	1	1	(16,17)
16	306111	Knife Lever Base	ナイフレバー土台	1	1	
17	3A03020	Needle Bearing (SCE48P)	ニードルベアリング	2	2	
18	4B5 × 40	Screw for 306111	ネジ	2	2	
19	306101	Knife Lever Pin	ナイフレバーピン	1	1	
20	306121	Knife Lever Spring	ナイフレバースプリング	1	1	
		Thread Pusher Set	糸押込み装置			
21	305301A	Thread Pusher Set	糸押エ込ミセット	(1)	(1)	(22-34)
22	305301	Lever Base	袋押エレバー土台	(1)	(1)	
23	3S5 × 15	Screw for 305301	ネジ	(2)	(2)	
24	285501	Spring Hook	スプリングフック	(1)	(1)	
25	2W5	Washer	座金	(1)	(1)	
26	4S5 × 5	Screw	ネジ	(1)	(1)	
27	285491	Spring	スプリング	(1)	(1)	
28	285461	Lever	袋押エレバー	(1)	(1)	
29	285471	Set Collar	セットカラー	(1)	(1)	(30)
30	SS1032316	Screw	ネジ	(1)	(1)	
31	305311	Guide	袋ガイド	(1)	(1)	
32	305331	Rubber	クッション	(1)	(1)	
33	305321	Face Plate, lower	下面板	(1)	(1)	
34	11/64S40005	Screw	ネジ	(2)	(2)	

08 2. CUTTER PARTS (DS-9C,DS-9CW)

カッター関係

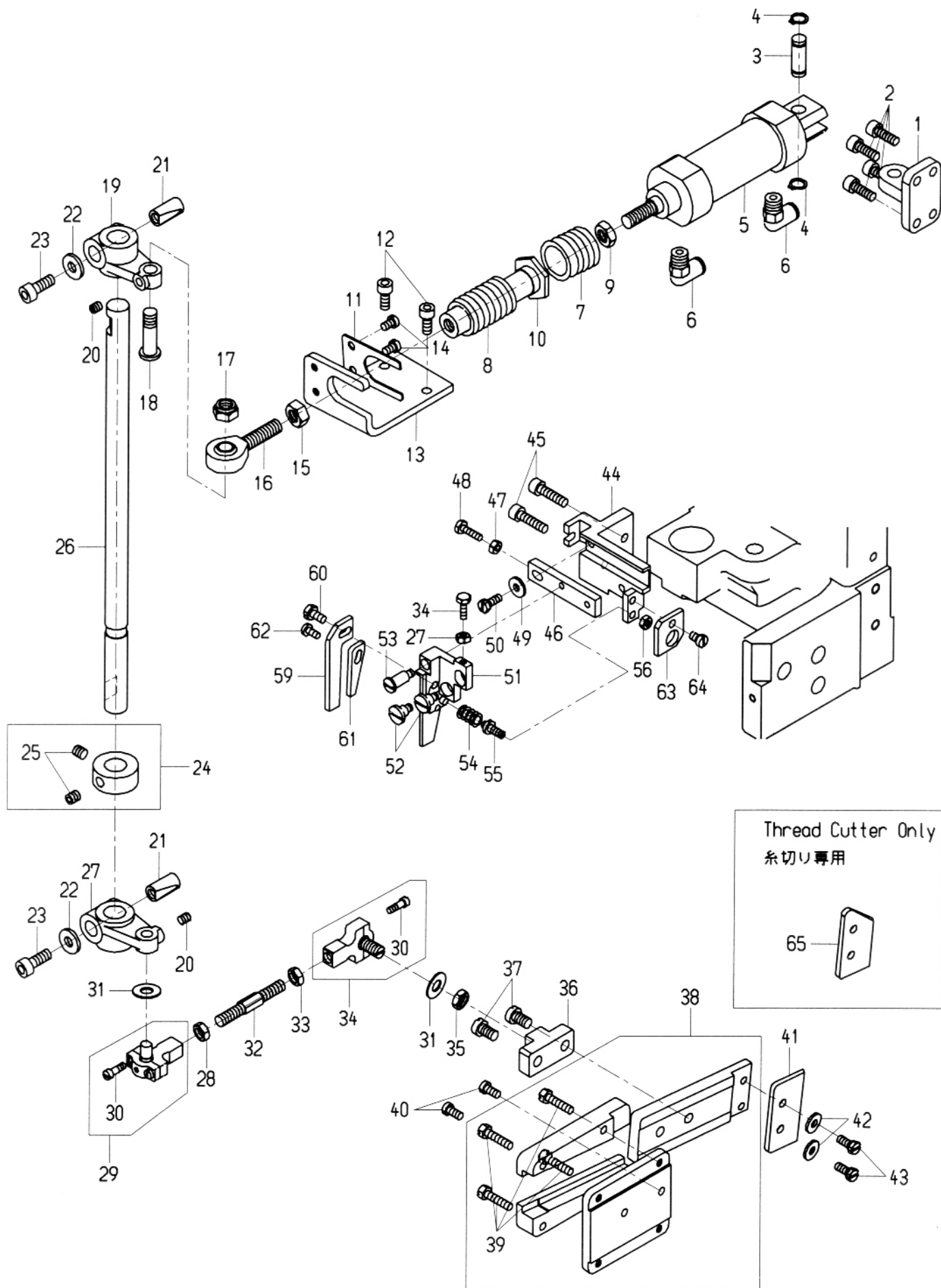

08 2. CUTTER PARTS (DS-9C,DS-9CW)

カッター関係

図番 Ref.No.	部品番号 Part No.	部品名称 Description	個数 Q ty		摘要 Remarks
			9C	9CW	
1	306011	Air Cylinder Base	1	1	
2	4B5 × 15	Screw for 306011	4	4	
3	106201	Pin	1	1	
4	1RS-8	Stop Ring (S-8)	2	2	
5	J01002	Air Cylinder	1	1	
6	D07034	Tube Fitting, elbow (PL6-01M)	2	2	
7	305221	Spring	1	1	
8	286161	Spring	1	1	
9	1N8C	Nut	1	1	
10	306151	Joint Rod	1	1	
11	306061	Spacer	1	1	
12	11/64S40005	Screw for 306061	2	2	
13	306032	Joint Rod Guide	1	1	
14	4B5 × 12	Screw For 306032	2	2	
15	1N8	Nut (M8)	1	1	
16	6A04007	Rod End (POS-8)	1	1	
17	6N5/16	Nut	1	1	
18	306162	Cutter Connecting Lever Pin	1	1	
19	306182	Cutter Connecting Lever	1	1	
20	1S5 × 6	Screw	2	2	
21	306191	Cotter Pin	2	2	
22	15/64W20101	Washer	2	2	
23	4B6 × 15	Screw	2	2	
24	062052	Set Collar	1	1	(25)
25	15/64S28525	Screw	2	2	
26	306171	Cutter Rocker Shaft	1	1	
27	306181	Cutter Connecting Lever	1	1	
28	1/4N32201	Nut	1	1	
29	063092A	Ball Joint Ass y, left	1	1	(30)
30	9/64S40061	Screw for 063092A, 063072A	4	4	
31	9/32W10106	Washer	2	2	
32	106141	Cutter Connecting Rod	1	1	
33	1/4N32201L	Nut	1	1	
34	063072A	Ball Joint Ass y, right	1	1	(30)
35	9/32N28210	Nut	1	1	
36	306041	Ball Holder	1	1	
37	15/64S28004	Screw for 306041	2	2	
38	106032C	Oscillating Plate Ass y	1	1	(39)
39	11/64S40061	Screw	4	4	
40	11/64S40006	Screw for 106032C	2	2	
41	106053	Upper Knife	1	1	
42	11/64W15103	Washer for 106053	2	2	
43	11/64S40049	Screw for 106053	2	2	
44	106062	Lower Knife Base Connection	1	1	
45	3/16S28018	Screw for 106062	2	2	
46	106152	Lower Knife Adjust Plate	1	1	
47	9/64N40101	Nut	1	1	
48	9/64S40067	Screw	1	1	
49	11/64W15103	Washer	1	1	
50	11/64S40075	Screw	1	1	
51	106072	Lower Knife Base	1	1	
52	11/64S40060	Screw	2	2	
53	11/64S40059	Screw	1	1	
54	106171	Spring	1	1	
55	106161	Spring Adjust	1	1	
56	11/64N40102	Nut for 106161	1	1	
57	9/64S40039	Screw	1	1	
58	9/64N40101	Nut	1	1	
59	106083	Lower Knife	1	1	
60	11/64S40093	Screw for 106083	1	1	
61	106093	Lower Knife Stopper	1	1	
62	9/64S40005	Screw for 106093	1	1	
63	306141	Plate	1	1	
64	11/64S40005	Screw	1	1	
65	306201	Upper Knife (Thread Cutter Only)	(1)	(1)	

09. THREAD BREAK DETECTOR & BINDER PARTS

糸切れ検出・バインダー関係

Thread Break Detector by Roller
糸切れ検出ローラー方式

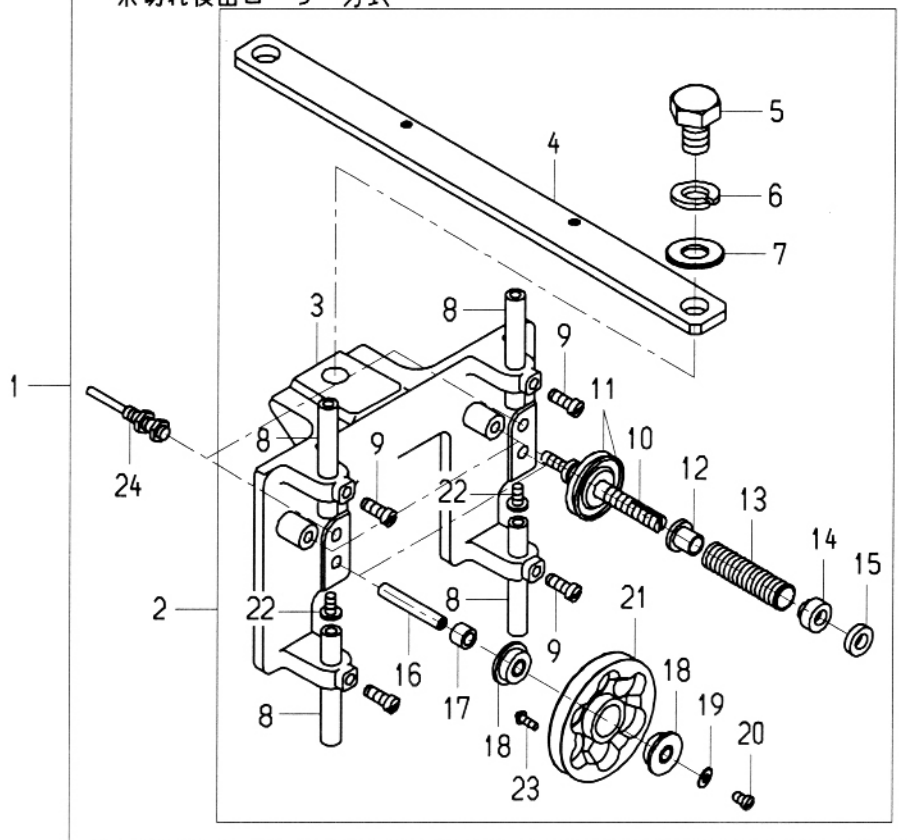

For Binder Set

バインダー装置

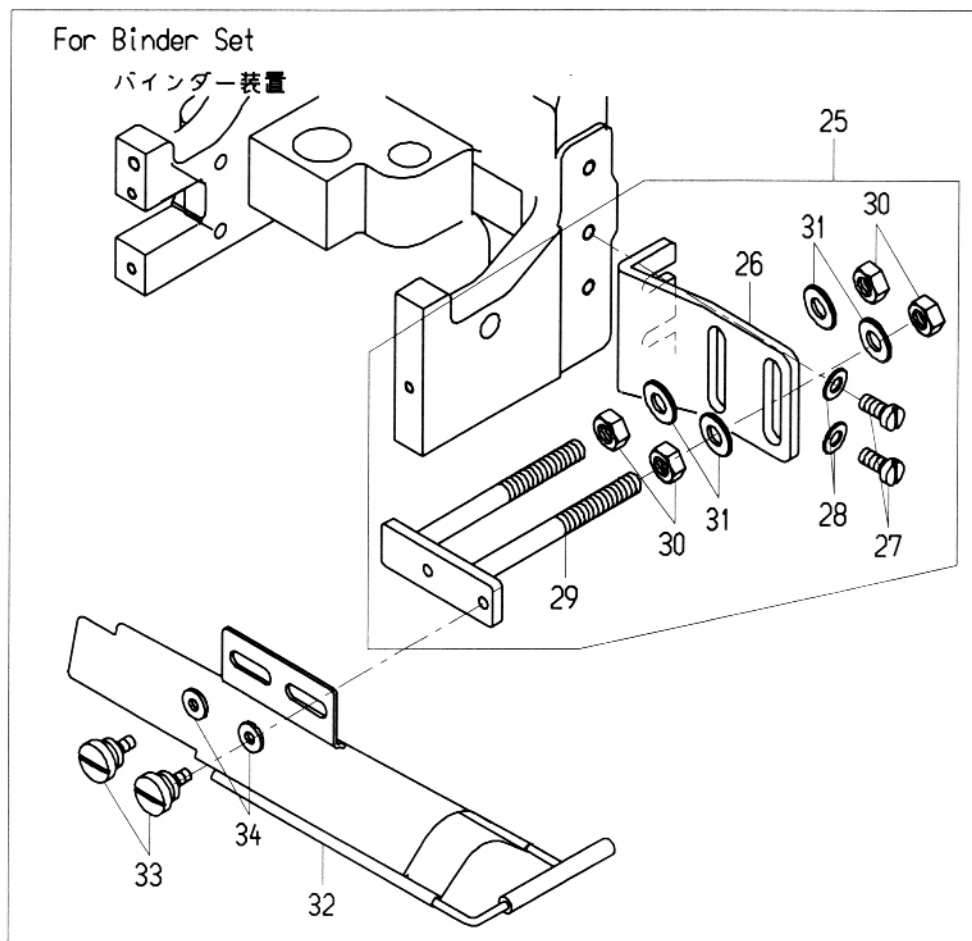

09. THREAD BREAK DETECTOR & BINDER PARTS

糸切れ検出・バインダー関係

図番 Ref.No.	部品番号 Part No.	部品名称 Description	個数 Q ty		摘要 Remarks
			9A	9C	
1	255531BS	Thread Break Detector Ass y	(1)	(1)	(2,24)
2	255531B	Thread Break Detector Ass y	(1)	(1)	(3-23)
3	255531	Thread Break Detector Base	(1)	(1)	
4	255571	Stay	(1)	(1)	
5	1B10 x 15	Bolt	(1)	(1)	
6	3W10	Spring Washer	(1)	(1)	
7	2W10	Washer	(1)	(1)	
8	075091	Frame Thread Eyelet	(4)	(4)	
9	11/64S40003	Screw for 075091	(4)	(4)	
10	035021	Tension Post	(2)	(2)	
11	065261	Tension Disc	(4)	(4)	
12	035071	Tension Post Ferrule	(2)	(2)	
13	51292F-2	Tension Spring	(2)	(2)	
14	065171	Tension Nut	(2)	(2)	
15	245091	Tension Nut	(2)	(2)	
16	255551	Shaft	(2)	(2)	
17	255561	Collar	(2)	(2)	
18	1A01015	Bearing	(4)	(4)	
19	2W3	Washer	(2)	(2)	
20	4S3 x 8	Screw	(2)	(2)	
21	255542	Thread Break Detector Roller	(2)	(2)	
22	4S4 x 10	Screw	(2)	(2)	
23	9S2.6 x 8	Screw	(12)	(12)	
24	C02010	Switch (FL7M-P8A6)	(2)	(2)	
25	105123A	Binder Base Set	-	(1)	(26-31)
26	105123	Binder Base	-	(1)	
27	15/64S28021	Screw for 105123	-	(2)	
28	2W6	Washer	-	(2)	
29	075212	Binder Base	-	(1)	
30	1N8	Nut for 075212	-	(4)	
31	2W8	Washer for 075212	-	(4)	
32	003101	Binder (55mm)	-	(1)	
33	3/16S32004	Screw for 003101	-	(2)	
34	11/64W15103	Washer for 003101	-	(2)	

							
3/32S56004	9/64S40003	9/64S40004	9/64S40005	9/64S40011	9/64S40039	9/64S40061	9/64S40066
							
9/64S40067	9/64S40502	11/64S40001	11/64S40002	11/64S40003	11/64S40005	11/64S40006	11/64S40009
							
11/64S40014	11/64S40018	11/64S40043	11/64S40045	11/64S40049	11/64S40059	11/64S40060	11/64S40061
							
11/64S40064	11/64S40073	11/64S40074	11/64S40075	11/64S40084	11/64S40090	11/64S40093	11/64S40100
							
11/64S40501	11/64S40505	3/16S28005	3/16S28014	3/16S28018	3/16S28028	3/16S32004	1/4S40010
							
7/32S32007	15/64S28004	15/64S28012	15/64S28017	15/64S28019	15/64S28021	15/64S28525	9/32S28001
							
1S5x5	1S5x6	1S5x8T	1S5x10	SS1032316	SS142838		
							
1S6x6	1S6x8	1S6x8T	1S6x10	1S6x12	9/32S28015		

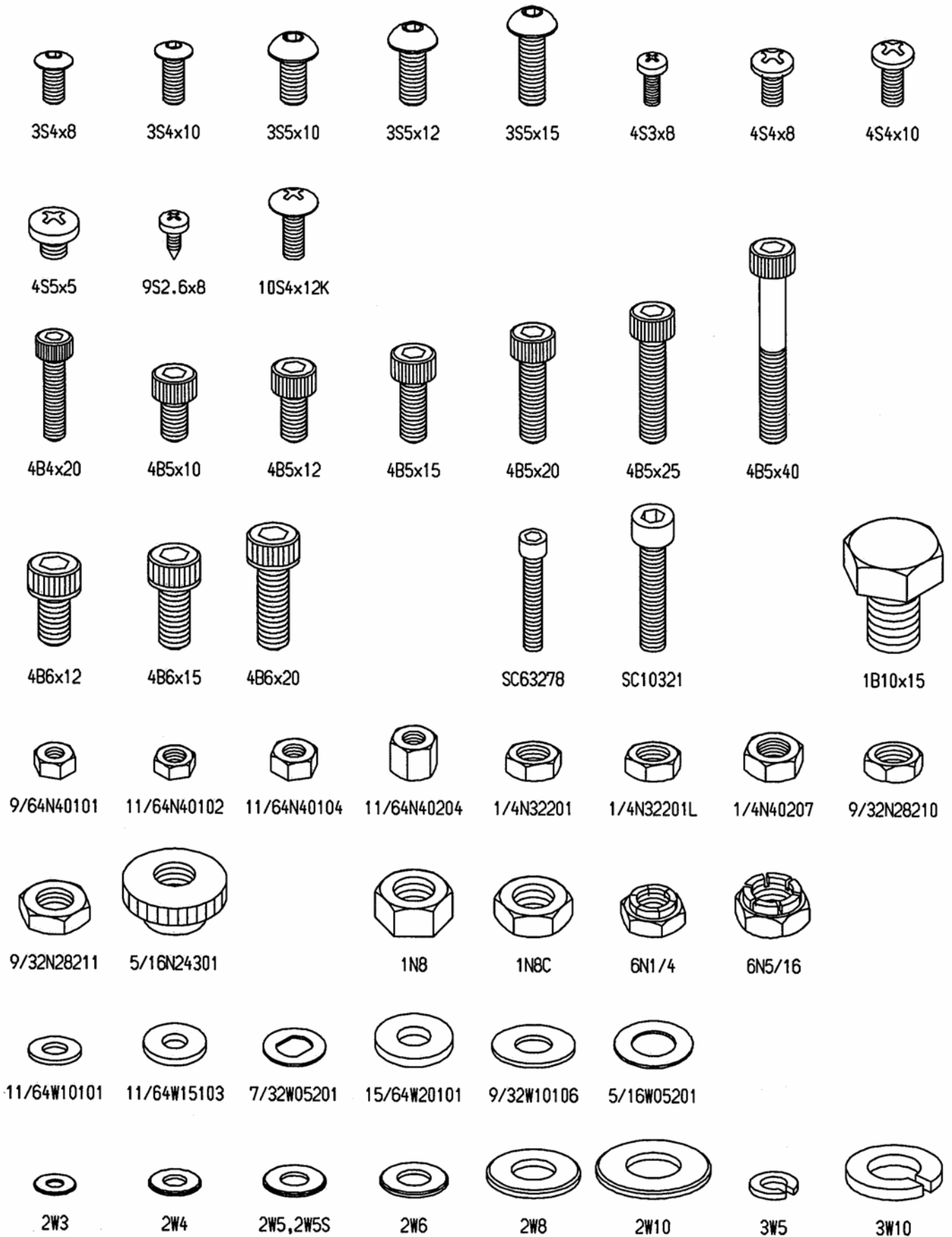

NUMERICAL INDEX OF PARTS

パーツ索引

PART NO.	PAGE	PART NO.	PAGE	PART NO.	PAGE	PART NO.	PAGE
003101	39-32	065401	17-13,19-24	112061	23-23	302261	25-34
015011	21-23	066133	35-11	114131	31-40,33-45	302271	25-37
031082	23-5	066143	35-9	245071	19-7	303011	29-6
031091	23-1	072121	27-9	245091	39-15	303021	29-13
031111	23-4	075081	19-9	255262	19-22	303031	23-18
031131	25-6	075091	19-11,21-12	255351	17-29	303041	23-16
032012A	25-8	075091	39-8	255392	19-39	303051	29-10
032022	25-14	075212	39-29	255392A	19-38	303061	29-14
032141	25-23	092052	23-25	255531	39-3	303072	29-48
032171	25-25	092062	23-30	255531B	39-2	303082	29-45
033022A	29-1	102062	27-6	255531BS	39-1	303082A	29-44
033072	29-16	102091	27-3	255542	39-21	303091	29-40
033121	29-27	102101	27-4	255551	39-16	303101	29-42
033301	29-54	102134A	27-28	255561	39-17	303111	23-33
035011	21-24	102135A	27-21	255571	39-4	303112	23-40
035021	21-18,39-10	102136A	27-27	281122	25-44	303121	23-35
035021A	21-17	102161	27-29	282121	27-12	303131	29-37
035022	21-26	102162	27-26	282242	27-14	303141	29-38
035022A	21-25	102171	27-1	285461	35-28	303151	29-32
035031	19-14,21-29	102261	27-35	285471	35-29	303161	29-30
035042	19-18	102281A	27-36	285491	35-27	303171	29-26
035043	21-33	102311A	27-38	285501	35-24	303181	29-22
035061	21-21	102321A	27-30	286161	37-8	303191	29-53
035071	21-20,39-12	102331A	27-39	301021	25-5	303211	29-55
035191	17-31	103021	29-35	301031	23-20	304011	31-5,33-5
035201	17-32	104033	31-22	301041	23-7	304021	31-2,33-2
035821	17-30	104072	33-36	301051	25-2	304021A	31-1,33-1
062052	25-19,37-24	104093	33-42	301061A	25-40	304031	31-11,33-11
062151	25-28	104122	33-43	301081	25-41	304041	31-8,33-8
062181	27-8	104123	33-40	301091	23-39,25-46	304051	31-12,33-14
062201	23-31	104231	33-50	302011	25-21	304061	29-11,31-13
062251A	27-31	104232	33-53	302021	25-22	304061	33-15
062252A	27-34	104241	33-51	302032	23-28	304071	33-22
062261	27-33	104242	33-54	302041	23-14	304082	31-27,33-30
062381	27-40	105017B	17-1	302052	23-13	304082A	31-26,33-29
062391A	27-41	105123	39-26	302061	23-12	304091	31-25,33-28
062392A	27-42	105123A	39-25	302072	25-16	304101	31-30,33-33
063072A	37-34	105521	19-42,21-5	302082	25-17	304112	33-18
063072AA	29-18	105561	21-15	302091A	25-27	304112A	33-17
063092A	37-29	106032C	37-38	302101	25-30	304121	33-25
063092AA	29-24	106053	37-41	302121	27-5	304131	33-37
064051	33-12	106062	37-44	302161A	27-46	304171	33-44
065044	17-3	106072	37-51	302191	27-48	304181	31-36
065151	19-2	106083	37-59	302201	27-44	304182	31-38
065151E	19-1	106093	37-61	302211	27-45	304191	31-19
065171	19-6,21-22	106141	37-32	302221	27-43	304191A	31-18
065171	39-14	106152	37-46	302222	27-11	304201	31-15
065181	19-5	106161	37-55	302231	27-51	304211	31-33
065211	19-13,19-46	106171	37-54	302251	25-33	304221	31-47
065261	21-19,39-11	106201	37-3	302251A	25-32	304231	31-48

NUMERICAL INDEX OF PARTS

パーツ索引

PART NO.	PAGE	PART NO.	PAGE	PART NO.	PAGE	PART NO.	PAGE
304241	31-49	306011	37-1	SCREW (ネジ)		15/64S28004	37-37
304251	33-21	306032	37-13			15/64S28012	25-1,25-12
304261	31-17	306041	37-36	3/32S56004	31-41,33-46	15/64S28017	17-46
304281	31-42	306061	37-11	9/64S40003	29-57	15/64S28019	27-7,27-10
304291	31-43	306072	29-51,35-1	9/64S40004	17-23,17-28		33-13
304301	31-44,33-52	306081	35-3	9/64S40005	19-43,21-6	15/64S28021	39-27
304311	31-39	306091	35-7		37-62	15/64S28525	25-20,35-8
305012	17-14	306101	35-19	9/64S40011	19-19,21-34		37-25
305021	17-21	306111	35-17		27-16	1/4S40010	25-12,29-4
305031	17-34	306111A	35-15	9/64S40039	37-57	9/32S28001	25-11
305042	17-8	306121	35-20	9/64S40061	29-2,37-30	9/32S28015	25-10
305052	17-7	306131	35-13	9/64S40066	29-56		
305062	17-40	306141	37-63	9/64S40067	37-48		
305072	17-39	306151	37-10	9/64S40502	31-21,33-24		
305081	17-19	306162	37-18	11/64S40001	25-35,25-37		
305082	17-17	306171	37-26	11/64S40002	25-26,31-23	1B10 × 15	39-5
305091	17-16	306181	37-27	11/64S40003	29-28,39-9	4B4 × 20	25-15
305111	17-11	306182	37-19	11/64S40005	17-4,17-24	4B5 × 10	17-36,25-31
305122	17-35	306191	37-21		17-38,17-50	4B5 × 12	29-41,37-14
305131	19-20,21-37	306201	37-65		29-25,29-43	4B5 × 15	21-11,37-2
305141	17-30	707181	23-38	11/64S40005	33-26,35-34	4B5 × 20	17-15,25-42
305151	17-5	HA1348	19-3		37-12,37-64		35-4
305152	17-53	51292F-2	39-13	11/64S40006	21-36,37-40	4B5 × 25	21-9,35-14
305162	17-45	80667	19-8	11/64S40009	19-17,21-32	4B5 × 40	35-18
305171	17-44	80676A	19-4		29-17	4B6 × 12	29-7
305181	27-18	032022	25-14	11/64S40014	19-15,21-30	4B6 × 15	29-15,37-23
305201	17-55	181131	31-9, 33-9	11/64S40018	27-47,29-36	4B6 × 20	29-52,35-2
305211	17-54			11/64S40043	27-17	1S5 × 5	19-21,21-14
305221	37-7			11/64S40045	27-49		21-16,21-38
305231	19-27			11/64S40049	37-43		31-24,33-27
305241	17-42			11/64S40059	37-53	1S5 × 6	19-12,25-24
305242	17-51			11/64S40060	37-52		29-9,29-34
305251	19-37			11/64S40061	37-39		37-20
305261	17-37			11/64S40064	27-32	1S5 × 8T	29-33
305271	17-49			11/64S40073	27-22	1S5 × 10	27-13
305281	17-52			11/64S40074	31-37,33-41	1S6 × 6	29-39,31-16
305291	19-36			11/64S40075	37-50		31-32,33-19
305301	35-22			11/64S40084	27-25,35-10		33-23,33-35
305301A	35-21			11/64S40090	25-9,29-3	1S6 × 8	29-12,31-14
305311	35-31			11/64S40093	37-60		33-16
305321	35-33			11/64S40100	27-37	1S6 × 8T	29-8
305331	35-32			11/64S40501	19-10	1S6 × 10	25-3,29-49
305361	21-10			11/64S40505	31-34,33-38		31-7,31-31
305371	21-8			3/16S28005	23-6		33-7,33-34
305381	21-35			3/16S28014	23-2	1S6 × 12	29-50,31-6
305391	21-39			3/16S28018	17-56,25-7	1S6 × 12	33-6
305401	21-2				37-45	3S4 × 8	17-6
305401A	21-1			3/16S28028	35-12	3S4 × 10	19-23,21-40
305431	21-27			3/16S32004	17-48,39-33		27-20
305441	21-13			7/32S32007	17-2	3S5 × 10	17-12,25-18

NUMERICAL INDEX OF PARTS

パーツ索引

PART NO.	PAGE	PART NO.	PAGE	PART NO.	PAGE	PART NO.	PAGE
3S5 × 12	17-9	WASHER (ワッシャー)		OTHER PARTS (其の他)			
3S5 × 15	17-41,19-45	11/64W10101	17-43,27-19	1A01002	23-3		
	35-23		27-50	1A01004	23-8		
4S3 × 8	39-20	11/64W15103	19-16,21-31	1A01015	39-18		
4S4 × 8	19-28						
4S4 × 10	39-22	11/64W15103	37-42,37-49	1A01020	29-29		
4S5 × 5	35-26		39-34	3A03013	29-47,31-3		
9S2.6 × 8	39-23	7/32W05201	27-15		33-3		
10S4 × 12K	17-18,17-33	15/64W20101	37-22	3A03014	23-32		
		9/32W10106	29-19,37-31	3A03016	23-22		
SC63278	17-20	5/16W05201	17-47,35-6	3A03018	31-4,33-4		
SC10321	25-43	2W3	39-19	3A03019	31-28,33-31		
SS1032316	35-30	2W4	19-29	3A03020	29-46,31-20		
SS142838	25-45	2W5	35-25		31-29,33-20		
		2W5S	35-5		33-32,35-17		
NUT (ナット)		2W6	39-28	4A01001	23-11		
		2W8	39-31	4A01002	23-10		
9/64N40101	37-47,37-58	2W10	39-7	6A04007	37-16		
11/64N40102	27-24,37-56	3W5	27-23	B05001	25-39		
11/64N40104	21-28	3W10	39-6	B20001	25-29,25-36		
11/64N40204	31-35,33-39			C02010	39-24		
1/4N32201	29-23,37-28			D03002	19-44,21-7		
1/4N32201L	29-21,37-33			D04003	23-9		
1/4N40207	25-13,29-5			D04011	23-15,23-34		
9/32N28210	29-20,37-35			D04012	23-19		
9/32N28211	31-10,33-10			D04013	23-21		
5/16N24301	27-2			D04014	23-29		
				D04015	23-26		
				D04016	23-24		
				D05003	19-25		
1N8	37-15,39-30			D05007	19-26		
1N8C	37-9			D07034	37-6		
6N1/4	29-31			D07055	19-32		
6N5/16	37-17			D07056	19-33		
				D07057	19-40,21-3		
				D09002	19-31		
				D09005	19-34		
				E07001	17-22		
				E07002	17-25		
				E07003	17-27		
				8FU2-4 × 130	19-41,21-4		
				11G1/8NPT	17-10,19-35		
				J01002	37-5		
				1K4 × 35S	25-4		
				31LP21	23-17,23-27		
				32LS14	23-37		
				1RS-8	17-26,37-4		
				3P1.2 × 20	23-36		

MODEL
DS-9A
DS-9C
DS-9P
DS-9AW
DS-9CW



ニューロング工業株式会社

〒125-0063 東京都葛飾区白鳥 4 - 8 - 14
本社営業本部 TEL03(3603)2284(代) FAX03(3603)2253

NL工業グル - プホ - ムペ - ジ URL / E-mail

URL <http://nlwww.com/>
E-mail info@nlwww.com